

## ■ STBV60 Series up to 6000 psi

## ■ STBVC Series CNG/NGV Valves up to 3770 psi

### Features

- Working pressure up to 6,000psi(413bar)@100°F(38°C).
- Compact, maximum flow design.
- Panel mountable as standard.
- Handle indicates flow direction.
- Low torque actuation.
- 2-way "Shut-up" and 3-way "Switching" type.
- Various end connections : include S-LOK Tube Fittings, NPT / ISO male & female.
- Optional sour gas service to NACE MR 0175.
- Every valve is 100% factory tested.



### Technical Data

Valve Series	Seat Material	Temperature Rating °C (°F)	Pressure Rating @38 °C (100°F)
STBV60	PCTFE	-17 to 121 (0 to 250)	6,000psig (413bar)
	PEEK	-17 to 232 (0 to 450)	6,000psig (413bar)
	PTFE		1,500psig (103bar)

### Testing

- The rated pressure shown above is the maximum allowable pressure to the seat. If the system requires higher pressure to test, the valve must be in open position before and during test so as not to damage the seat.
- Every valve is factory tested for bubble - tight leakage at both seat and stem packing with nitrogen at 1000psi(69bar).
- Hydraulic shell test is performed at 1.5times the working pressure.
- Seats have a maximum allowable leak rate of 0.1 SCCM.
- Optional tests are available upon request.

### CNG / NGV Information

- STBVC Series valve provides leak - tight integrity in both low and high pressure systems in CNG and NGV applications. Valves with peek seat and HNBR O-ring are compatible with CNG fluid.

Valve Series	Certificates	ECE R110	ANSI NGV 3.1-2012	ISO 15500
STBVC Series 2-Way	Certificate No.	110R-010333	126840AUT14	126840MECH103
	Classification	Class 0	Manual valve	Manual valve
	Temperature	-40 to 120°C (-40 to 248°F)	-40 to 120°C (-40 to 248°F)	-40 to 120°C (-40 to 248°F)
	Working Pressure	260 bar @ 120 °C	248 bar @ 120 °C	260 bar @ 120 °C
STBVC Series 3-Way	Certificate No.	110R-000184	110R-000184	110R-000184
	Classification	Class 0	Manual valve	Manual valve
	Temperature	-40 to -120°C (-40 to 248°F)	-40 to -120°C (-40 to 248°F)	-40 to -120°C (-40 to 248°F)
	Working Pressure	260 bar @ 38 °C	260 bar @ 38 °C	260 bar @ 38 °C

## Materials of Construction

### STBV60 & STBVC 2-Way

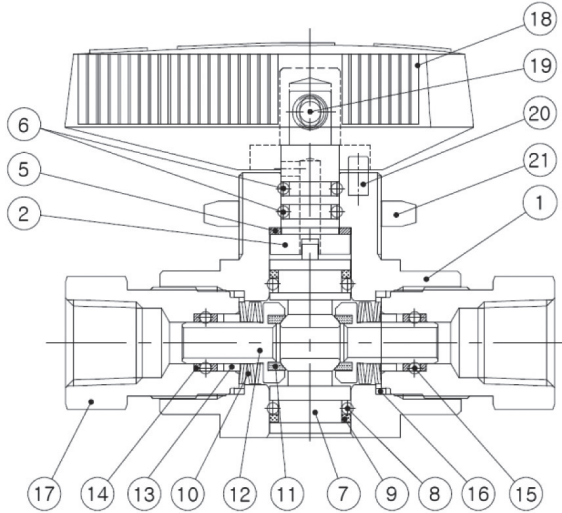

### STBV60 & STBVC 3-Way

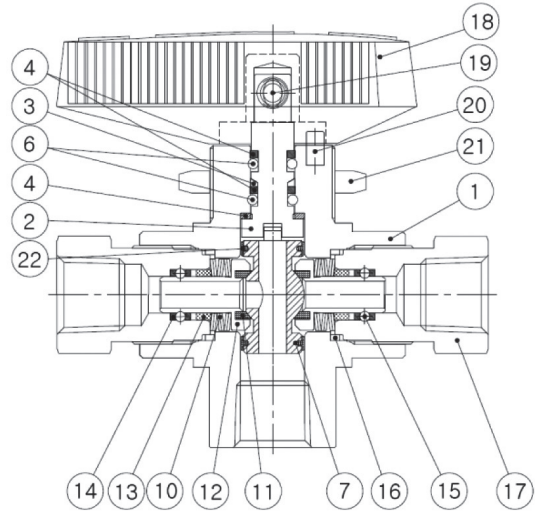

Item	Description	STBV60 Series		STBVC Series	
		2-Way	3-Way	2-Way	3-Way
Grade/ASTM Specification					
1	Body	S316 / A276 or A479			
2	Stem*	S316 / A276 or A479			
3	Stem Support Ring*	-	PEEK	-	PEEK
4	Stem Backup Ring*	-	PTFE	-	PTFE
5	Stem Bearing*	PEEK			
6	Stem O-Ring*	FKM		HNBR	
7	Trunnion Ball*	S316 / A276 or A479			
8	Ball O-Ring*	FKM	-	HNBR	-
9	Ball Backup Ring*	PTFE	-	PTFE	-
10	Disc Spring*	Alloy X-750 / AMS 5542			
11	Seat*	PCTFE, optional PTFE, PEEK		PEEK	
12	Seat Carrier*	S316 / A276 or A479			
13	Seat Carrier Guide*	S316 / A276 or A479			
14	Seat Carrier Backup Ring*	PTFE			
15	Seat Carrier O-Ring*	FKM		HNBR	
16	End Connector Packing*	PTFE / D1710, Type 1			
17	End Connector	S316 / A276 or A479			
18	Handle*	Phenolic with brass insert			
19	Set Screw*	S316			
20	Stop Pin	S316			
21	Lock Nut	S316 / A276 or A479			
22	Slip Ring*	-	PTFE	-	PTFE

\* Service kits contain part

## Table of Dimensions

### STBV60 & STBVC 2-Way

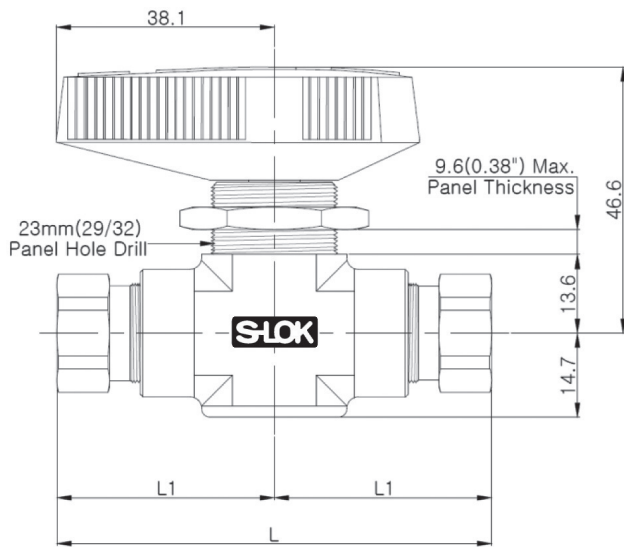

### STBV60 & STBVC 3-Way

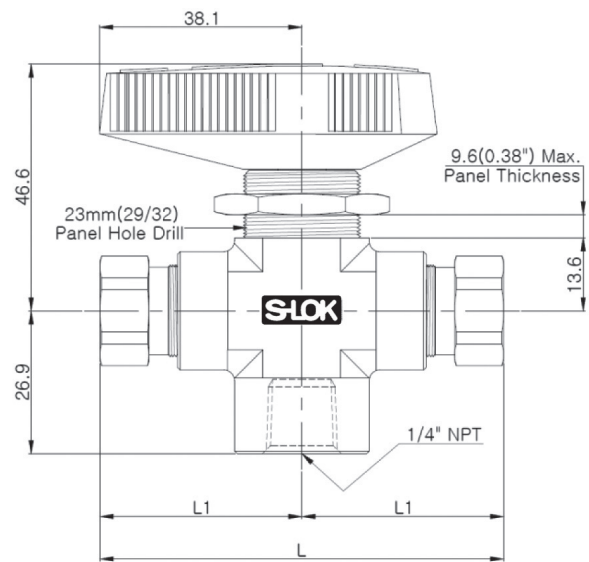

2-Way Valve Orifice 4.75mm (0.187 in.)					
STBV60 Series Ordering Numbers	End Connection		Cv	Dimensions mm(in.)	
	Inlet	Outlet		L	L1
STBV / STBVC	F-2N	1/8" Female NPT	1.2	76.2 (3)	38.1 (1.5)
	F-4N	1/4" Female NPT	1	76.2 (3)	38.1 (1.5)
	-	1/4" Female NPT	1	99.8 (3.93)	50 (1.97)
	F-8N	1/2" Female NPT	1.2	108 (4.25)	54.1 (2.13)
	S-4T	1/4" S-LOK	1.6	105 (4.14)	52.6 (2.07)
	S-6T	3/8" S-LOK	1.4	112 (4.41)	55.6 (2.19)
	S-8T	1/2" S-LOK	1	117 (4.6)	58.4 (2.3)
	S-6M	6mm S-LOK	1.6	105 (4.14)	52.6 (2.07)
	S-8M	8mm S-LOK	1.5	105 (4.14)	52.6 (2.07)
	S-10M	10mm S-LOK	1.3	112 (4.41)	55.9 (2.2)
S-12M	12mm S-LOK	1	117 (4.6)	58.4 (2.3)	
3-Way Valve Orifice 4.75mm (0.187 in.)					
STBV-3B / STBVC-3B	F-2N	1/8" Female NPT	0.75	76.2 (3)	38.1 (1.5)
	F-4N	1/4" Female NPT		76.2 (3)	38.1 (1.5)
	-	1/4" Female NPT		99.8 (3.93)	50 (1.97)
	S-4T	1/4" S-LOK		105 (4.14)	52.6 (2.07)
	S-6T	3/8" S-LOK		112 (4.41)	55.6 (2.19)
	S-8T	1/2" S-LOK		117 (4.6)	58.4 (2.3)
	S-6M	6mm S-LOK		105 (4.14)	52.6 (2.07)
	S-8M	8mm S-LOK		105 (4.14)	52.6 (2.07)
	S-10M	10mm S-LOK		112 (4.41)	55.9 (2.2)
	S-12M	12mm S-LOK		117 (4.6)	58.4 (2.3)

## Ordering Information

- Selection of the applicable options from the designators are listed below.

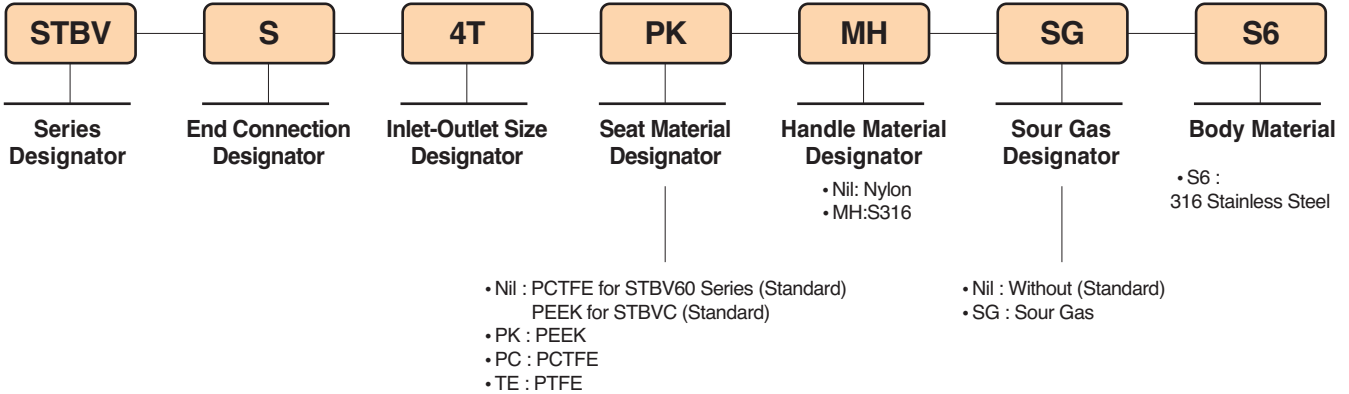

## Safety in Valve Selection

- When selecting a valve, the total system design must be considered to ensure safe, trouble - free performance.
- Valve function, materials compatibility, adequate ratings, proper installation, operation, and maintenance are the responsibility of the system designer and user.

## Service Kit

Service kits contain components of the same materials as new components.

To order the service kit, selection of the applicable options from the designators are listed mark(\*) of 19page.

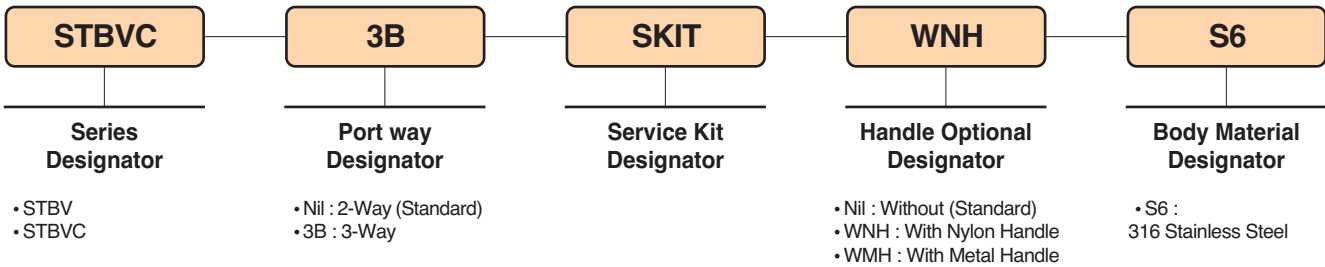

## SDBV Series Ball Valves for DIN Standard

### Features

- Pressure rating up to 500barg @ 21°C
- Temperature rating from -20°C to 100°C with POM and FKM(Viton) standard.
- Conforms to DIN standard.
- Compact design with maximum orifice.
- Variety of end connections such as DIN 2353 “L” & “S” series, Male & Female DIN / ISO/ BSP and NPT threads.
- Handle is only available in cast stainless steel standard.
- Every valve is 100% factory tested with the Nitrogen @1,000psig (68barg)

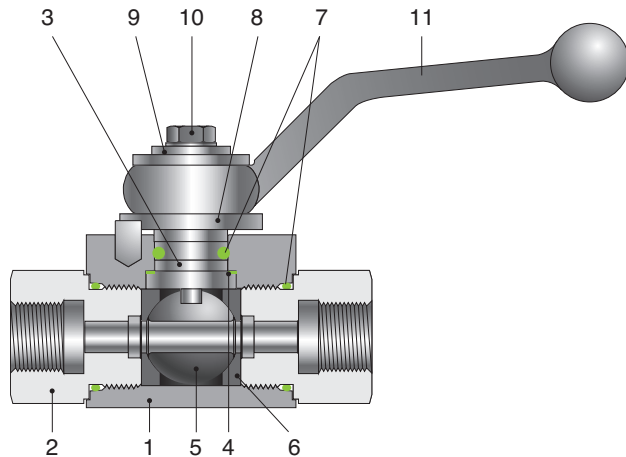
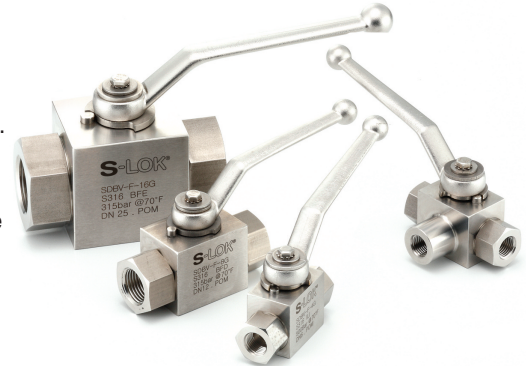

### Materials of Construction

Description		Grade / Specification
1	Body	S316/A479 or A276 DIN 17440/14571
2	End Connector	
3	Stem	
4	Stem Bearing	PTFE
5	Ball	S316/A479 or A276 DIN 17440/14571
6	Ball Seats	POM – MoS2 (Standard)
7	Stem & End Seals	Fluorocarbon FKM O-ring
8	Locking Device	Stainless Steel
9	Upper Washer	Stainless Steel
10	Bolt	Stainless Steel
11	Handle	S316

### Temperature Rating

#### Seals

Materials	Temperature Rating
NBR	-23 °C to 121 °C
FKM	-23 °C to 200 °C
EPDM	-46 °C to 149 °C

#### Ball Seats

Materials	Temperature Rating
POM – MoS2	-30 °C to 100 °C
PTFE	-54 °C to 65 °C

### Test

- Every valve is factory tested with bubble-tight leakage test at both seat and stem packing with nitrogen at 1,000psig (69barg)
- Hydraulic shell test is performed at 1.5 times the working pressure.
- Seats have a maximum allowable leakage rate of 0.1 SCCM Optional tests are available upon request

### Safety in Valve Selection

When selecting a valve, the total system design must be considered to ensure safe, trouble-free performance. Valve function, materials compatibility, adequate ratings, proper installation, operation, and maintenance are the responsibility of the system designer and user.

## Product Information

### Table of Dimensions

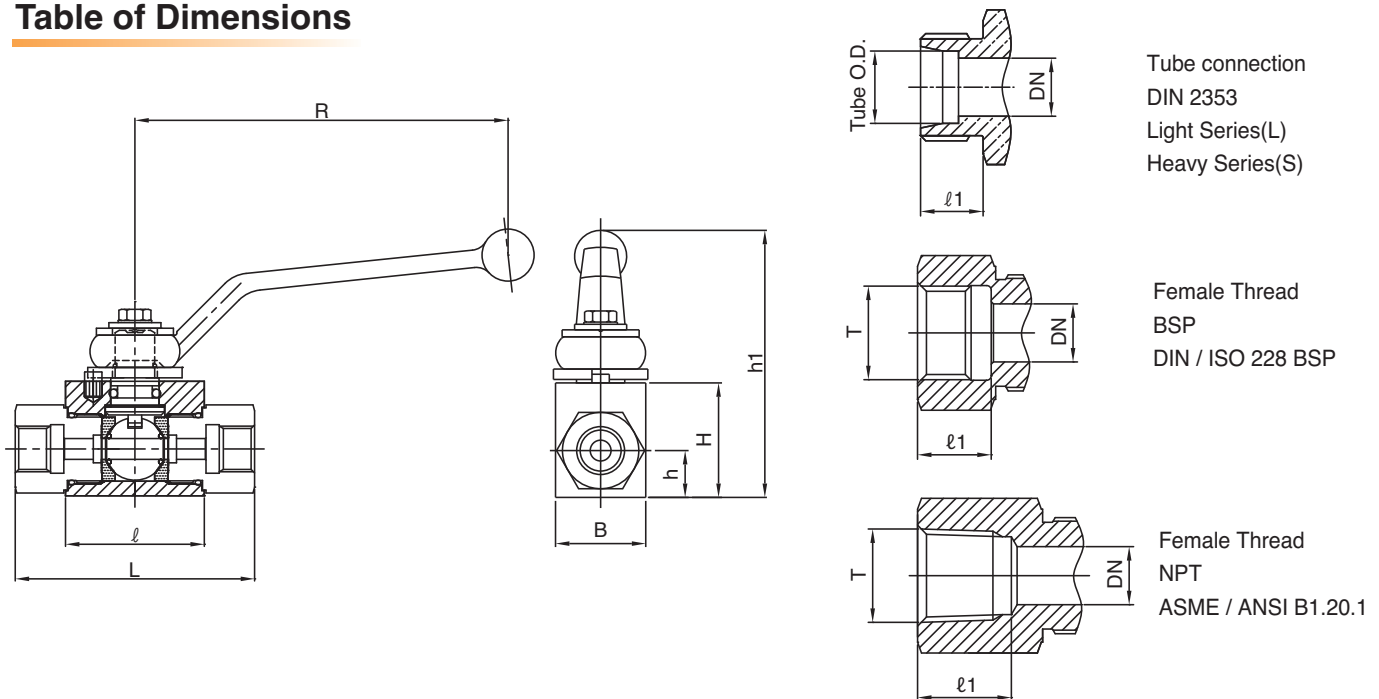

#### DIN 2353 Light(L) Tube Series

Basic Ordering Number	End Connections Inlet & Outlet	DN	PB	Dimensions (mm)								Weight (kg)
				B	H	h	h1	L	$\varnothing$	$\varnothing 1$	R	
SDBV1 – 6L	6MM	4	315	26	33	13.5	82	67	40	10	115	0.4
SDBV1 – 8L	8MM	6	315	26	33	13.5	82	67	40	10	115	0.4
SDBV1 – 10L	10MM	6	315	26	33	13.5	82	74	40	11	115	0.5
SDBV2 – 12L	12MM	10	315	32	38	17.5	87	74	43	11	115	0.6
SDBV3 – 15L	15MM	13	315	35	40	19	89	82	48	12	115	0.7
SDBV3 – 18L	18MM	13	315	35	40	19	89	82	48	12	115	0.8
SDBV4 – 22L	22MM	20	160	49	57	24.5	114	101	62	14	159	2.1
SDBV5 – 28L	28MM	25	160	58	65	29.5	122	108	66.2	14	159	2.3
SDBV5 – 35L	35MM	25	160	58	65	29.5	122	112	66.2	16	159	2.3

#### DIN 2353 Heavy (S) Tube Series

Basic Ordering Number	End Connections Inlet & Outlet	DN	PB	Dimensions (mm)								Weight (kg)
				B	H	h	h1	L	$\varnothing$	$\varnothing 1$	R	
SDBV1 – 8S	8MM	4	500	26	33	13.5	82	73	40	12	115	0.4
SDBV1 – 10S	10MM	6	500	26	33	13.5	82	73	40	12	115	0.4
SDBV2 – 12S	12MM	6	500	32	38	13.5	82	76	43	12	115	0.5
SDBV2 – 14S	14MM	10	500	32	38	17.5	87	80	43	14	115	0.6
SDBV3 – 16S	16MM	13	400	35	40	19	89	86	48	14	115	0.7
SDBV3 – 20S	20MM	13	400	35	40	19	89	90	48	16	115	0.8
SDBV4 – 25S	25MM	20	315	49	57	24.5	114	109	62	18	159	2.1
SDBV5 – 30S	30MM	25	315	58	65	29.5	122	120	66.2	20	159	2.3
SDBV5 – 38S	38MM	25	315	58	65	29.5	122	124	66.2	22	159	2.3

## Product Information

### Female DIN / ISO 228 / BSP

Basic Ordering Number	End Connections Inlet & Outlet	DN	PB	Dimensions (mm)								Weight (kg)
				B	H	h	h1	L	ℓ	ℓ1	R	
SDBV1-F-2G	PF 1/8	6	500	26	33	13.5	82	68.8	40	10	115	0.4
SDBV1-F-4G	PF 1/4	6	500	26	33	13.5	82	68.8	40	14	115	0.4
SDBV2-F-6G	PF 3/8	10	500	32	38	17.5	87	71.9	43	14	115	0.6
SDBV3-F-8G	PF 1/2	13	500	35	40	19	89	82.3	48	16.5	115	0.7
SDBV4-F-12G	PF 3/4	20	315	49	57	24.5	114	95.4	62	18	159	1.6
SDBV5-F-16G	PF 1	25	315	58	65	29.5	122	112.7	66.2	20	159	2.3
SDBV6-F-20G	PF1 1/4	32	315	75	82	37.5	165	121.6	68	22	260	4.36
SDBV7-F-24G	PF 1 1/2	38	315	95	99.1	47.5	182	130.2	85	24	260	6.8
SDBV8-F-32G	PF 2	50	315	115	115.2	57.5	198	140	100	26	260	9.44

### Female NPT (ANSI/ASME B1.20.1)

Basic Ordering Number	End Connections Inlet & Outlet	DN	PB	Dimensions (mm)								Weight (kg)
				B	H	h	h1	L	ℓ	ℓ1	R	
SDBV1-F-4N	NPT 1/4	6	500	26	33	13.5	82	68.8	40	15	115	0.4
SDBV2-F-6N	NPT 3/8	10	500	32	38	17.5	87	78	43	15	115	0.6
SDBV3-F-8N	NPT 1/2	13	500	35	40	19	89	104	48	20.5	115	0.7
SDBV4-F-12N	NPT 3/4	20	315	49	57	24.5	114	102	62	21.5	159	1.6
SDBV5-F-16N	NPT 1	25	315	58	65	29.5	122	119	66.2	25.4	159	2.3
SDBV6-F-20N	NPT 1 1/4	32	315	75	82	37.5	165	-	68	-	260	-
SDBV7-F-24N	NPT 1 1/2	38	315	95	99.1	47.5	182	-	85	-	260	-
SDBV8-F-32N	NPT 2	50	315	115	115.2	57.5	198	-	100	-	260	-

## Applications

- Hydraulic fluids, compressed air, lubricants, and fuel oil system.

## Sour Gas Service

- Is provided to meet NACE Standard MR0175.

## Ordering Information

- Selection of the applicable options from the designators are listed below.

<b>SDBV3</b>	<b>F</b>	<b>4G</b>	<b>TE</b>	<b>NB</b>	<b>LD</b>	<b>SG</b>	<b>S6</b>
Basic Ordering Number	End Connection Designator	Size Designator	Ball Seat Material Designator	Stem & End Seal Material Designator	Locking Device Designator	Sour Gas Designator	Material Designator
	<ul style="list-style-type: none"> <li>• F : Female Thread</li> <li>• M : Male Thread</li> </ul>		<ul style="list-style-type: none"> <li>• Nil : Standard POM-MoS2</li> <li>• TE : PTFE</li> </ul>	<ul style="list-style-type: none"> <li>• Nil : Standard FKM</li> <li>• NB : NBR</li> <li>• EP : EPDM</li> </ul>	<ul style="list-style-type: none"> <li>• Nil : Without (Standard)</li> <li>• LD : With</li> </ul>	<ul style="list-style-type: none"> <li>• Nil : Without (Standard)</li> <li>• SG : Sour Gas</li> </ul>	<ul style="list-style-type: none"> <li>• S6 : S316</li> <li>• CS : Carbon Steel</li> </ul>

## SPV Series Plug Valves

### Features

- Pressure rating up 3,000psig(206barg) @70°F(21°C)
- Temperature rating from -10 °F to 400°F(-23°C to 204°C) with PTFE coated Viton Seal
- Small and compact design
- Easy maintenance and cleaning
- Sizes available up to 1/2" tube and pipe
- Body materials available in 316 stainless steel and brass



### Material of Construction

Component	Valve Body Materials	
	Stainless Steel	Brass
	Grade/ASTM Specification	
1. Body	S316/ A479 or A276	Brass / B16
2. Plug	PTFE-coated S316/ A479 or A276	PTFE-coated Brass / B16
3. O-ring	PTFE-coated Viton Standard	
4. Handle	Nylon	
5. Pin	S316/A276	
6. Snap ring	Stainless Steel	

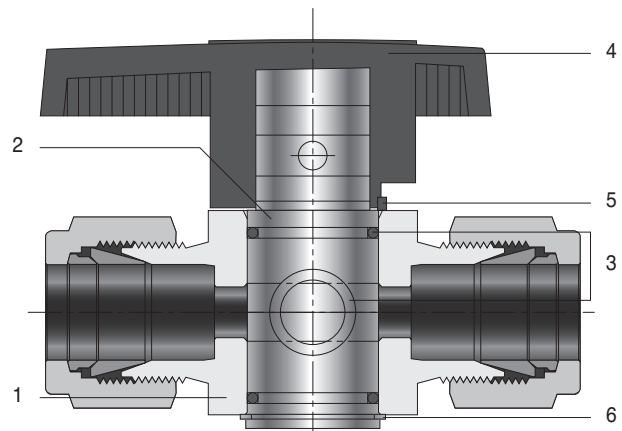

- Wetted parts and lubricants listed in Red.

### Pressure-Temperature Rating

Series	Valve Material	Pressure Rating		Temperature Rating	Plug Orifice mm (in.)
		Psig	Barg		
SPV1	S316	3,000	206	-10 to 400 °F (-23 to 204 °C)	4.4 (.17)
	Brass				
SPV2	S316	2,000	137		7.2 (.28)
	Brass				

- Differential pressure is limited to maximum 150 psig (10.3barg) when reverse flow occurs.
- Throttling reverse flow may damage O-ring.

### Testing

- Every valve is factory tested for shut off at 600psig (41barg)

### Optional O-ring Material

O-ring material	Temperature Range
Standard PTFE - coated Viton	-20 to 400°F(-28 to 204°C)
PTFE - coated NBR	-68 to 221°F(-20 to 105°C)
PTEF - coated EPDM	-49 to 275°F(-45 to 135°C)

- PTFE - coated Viton is standard. Choose optional O-ring material for fluid compatibility and system temperatures.

## Product Information

### Ordering Information and Dimensions

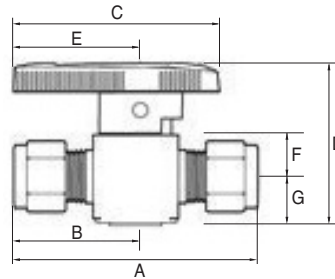

Basic Ordering Number	End Connections		Dimensions mm (inches)							
	Inlet	Outlet	A	B	C	D	E	F	G	H
SPV1	S-2T	1/8 S-Lok	50.5 (1.99)	19.8 (0.78)	47.8 (1.88)	38.6 (1.52)	29.0 (1.14)	9.4 (0.37)	11.7 (0.46)	19.1 (0.75)
	S-4T	1/4 S-Lok	55.1 (2.17)							
	S-6T	3/8 S-Lok	58.2 (2.29)							
	S-6M	6mm S-Lok	55.1 (2.17)							
	M-2N	1/8 M NPT	38.9 (1.53)							
	M-4N	1/4 M NPT	48.3 (1.90)							
	MS-4N4T	1/4 M NPT   1/4 S-Lok	51.2 (2.03)							
	MF-4N	1/4 M NPT   1/4 F NPT	50.8 (2.00)							
	F-2N	1/8 F NPT	45.2 (1.78)							
	F-4N	1/4 F NPT	53.1 (2.09)							
F-4R	1/4 F ISO tapered	56.1 (2.21)								
SPV2	S-6T	3/8 S-Lok	67.6 (2.66)	29.0 (1.14)	63.2 (2.49)	54.1 (2.13)	38.1 (1.50)	14.2 (0.56)	16.8 (0.66)	28.4 (1.12)
	S-8T	1/2 S-Lok	73.2 (2.88)							
	S-8M	8mm S-Lok	67.6 (2.66)							
	S-10M	10mm S-Lok	68.1 (2.68)							
	S-12M	12mm S-LOK	75.2 (2.96)							
	M-8N	1/2 M NPT	67.1 (2.64)							
	F-6N	3/8 F NPT	60.5 (2.38)							
	F-8N	1/2 F NPT	73.2 (2.88)							
F-8R	1/2 ISO F Tapered	79.8 (3.14)								

### Operation

- S-LOK plug valves provide positive shut-off, high flow capacity, and quick quarter-turn operation.
- S-LOK plug valve provides flow throttling capability.

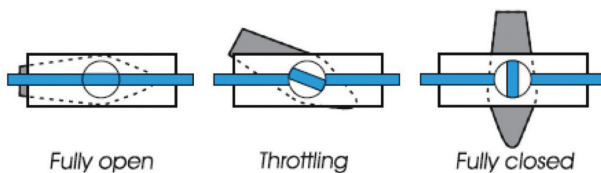

### Downstream Vent

- S-LOK plug valves provide positive shut-off, high flow capacity, and quick quarter-turn operation.
- S-LOK plug valve provides flow throttling capability.

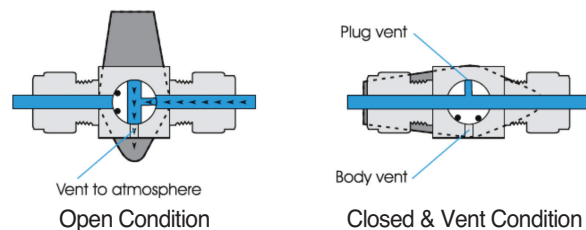

## Product Information

### Flow Rate

Basic Ordering Number	End Connections		Cv	Pressure Drop in the Atmosphere, psi (bar)						
	Inlet	Outlet		Air Flow, std ft <sup>3</sup> /min (L/min)			Water Flow, US gal/min(L/min)			
				@70 °F (21 °C)						
				1 (0.068)	5 (0.34)	10 (0.68)	1 (0.068)	5 (0.34)	10 (0.68)	
SPV1	S-2T	1/8 S-Lok	0.1	0.3 (8.4)	0.8 (22)	1.1 (31)	0.1 (0.37)	0.2 (0.75)	0.3 (1.1)	
	S-4T	1/4 S-Lok	1.6	6.0 (169)	13 (368)	18 (509)	1.6 (6.0)	3.6 (13.6)	5.1 (19.3)	
	S-6T	3/8 S-Lok	1.1	4.1 (116)	8.9 (252)	12.4 (351)	1.1 (4.1)	2.5 (9.4)	3.5 (13.2)	
	S-6M	6mm S-Lok	1.6	6.0 (169)	13 (368)	18 (509)	1.6 (6.0)	3.6 (13.6)	5.1 (9.3)	
	M-2N	1/8 M NPT	1.0	3.7 (104)	8.1 (229)	11.3 (320)	1.0 (3.7)	2.2 (8.3)	3.2 (12.1)	
	M-4N	1/4 M NPT								
	MS-4N4T	1/4 M NPT	1/4 S-Lok	0.9	3.3 (93)	7.3 (206)	101 (286)	0.9 (3.4)	2.0 (7.5)	2.8 (10.8)
	MF-4N	1/4 M NPT	1/4 F NPT	1.0	3.7 (104)	8.1 (229)	11.3 (320)	1.0 (3.7)	2.2 (8.3)	3.2 (12.1)
	F-2N	1/8 F NPT		1.2	4.4 (124)	9.7 (274)	13.5 (382)	1.2 (4.5)	2.7 (10.2)	3.8 (14.3)
	F-4N	1/4 F NPT		0.9	3.3 (93)	7.3 (206)	10.1 (286)	0.9 (3.4)	2.0 (7.5)	2.8 (10.8)
F-4R	1/4 F ISO tapered									
SPV2	S-6T	3/8 S-Lok	6.4	23.9 (676)	52.0 (1,470)	72.3 (3,040)	6.4 (24.2)	14.3 (54.1)	20.2 (76.4)	
	S-8T	1/2 S-Lok	4.4	16.4 (464)	35.7 (1,010)	49.7 (1,400)	4.4 (16.6)	9.8 (37.0)	13.9 (52.6)	
	S-8M	8mm S-Lok	6.4	23.9 (676)	52.0 (1,470)	72.3 (2,040)	6.4 (24.2)	14.3 (54.1)	20.2 (76.4)	
	S-10M	10mm S-Lok								
	S-12M	12mm S-LOK	4.8	17.9 (506)	39.0 (1,100)	54.2 (1,530)	4.8 (18.1)	10.7 (40.4)	15.2 (57.5)	
	M-8N	1/2 M NPT	2.4	9.0 (254)	19.5 (552)	27.1 (767)	2.4 (9.0)	5.4 (20.4)	7.6 (28.7)	
	F-6N	3/8 F NPT	4.3	16.0 (453)	34.9 (988)	48.6 (1,370)	4.3 (16.2)	9.6 (36.3)	13.6 (51.4)	
	F-8N	1/2 F NPT	2.7	10.1 (286)	21.9 (620)	30.5 (863)	2.7 (10.2)	6.0 (22.7)	8.5 (32.1)	
F-8R	1/2 ISO F Tapered									

### Ordering Information

- Select the desired valve's basic ordering number, option and body material.

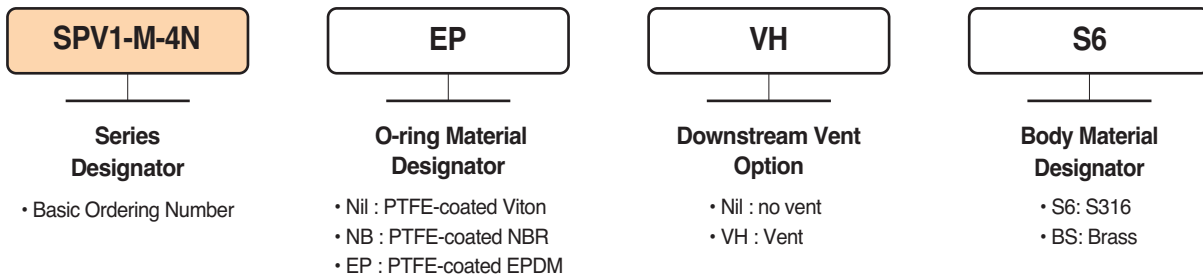

### Safe Valve Selection

- The selection of a valve for any application or system design must be considered to ensure safe performance. Valve function, valve rating, material compatibility, proper installation, operation and maintenance remain the sole responsibility of the system designer and the user. S-LOK accepts no liability for any improper selection, installation, operation or maintenance.



27 Noksansandan361-ro, Gangseo-gu  
(Songjeong-dong), Busan, Korea

Tel : +82-51-899-6700, Fax : +82-51-899-6799

E-Mail : [overseas@ehansun.co.kr](mailto:overseas@ehansun.co.kr)

[sales@ehansun.co.kr](mailto:sales@ehansun.co.kr)

Website : [www.ehansun.co.kr](http://www.ehansun.co.kr), [www.slok.co.kr](http://www.slok.co.kr)