

# Check, Relief & Excess Flow Valves

---

The best partner for value creation  
We support the innovations of customers



# 13

# SCV30 Series Check Valves

## Features

- Ensures Valve closes bubble tight

## Fixed Cracking Pressures

- From 1/3psi to 25psi

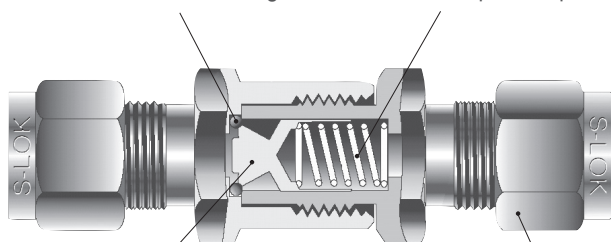

## Back stopped Poppet

- Minimize Spring stress

## Various End Connections

- include S-LOK Tube Fittings
- NPT & ISO Male/Female Threads



## Features

- Pressure rating up to 3,000psig (206bar)@70°F(21°C).
- Temperature rating up to 375°F(191°C) with Standard Viton O-ring.
- Choice of materials : Standard S316 and Brass.
- Cracking pressures include : 1/3, 1, 3, 10, 25, 50psi.
- Heat code traceability.
- Every valve is 100% factory tested for cracking and reseal.

## Technical Data

Valve Series	SCV1, SCV2, SCV3, SCV4	SCV5, SCV6
Max. Working Pressure @ 70°F(21°C)	S316 and Brass 3000psi (206bar)	S316 : 2000psi(137bar) Brass : 1500psi(103bar)
Operating Temperature Range	Viton : -10°F to 375°F(-23°C to 190°C) NBR : -4°F to 221°F(-20°C to 105°C)	
Nominal Cracking Pressure	1/3, 1, 3, 10, 25, 50psi	

## Cracking, Reseal and Back Pressure

### Cracking Pressure

The upstream pressure at which a detectable flow is Measured. The Check valve is actuated when the pressure difference between the inlet and the outlet reaches the range of cracking pressure.

### Reseal Pressure

The downstream pressure at which the check valve closes bubble-tight. The Check valves that have higher cracking pressure can be resealed to bubble-tight by the spring force. The reseal pressure is the pressure at the same flow direction, but lower than the cracking pressure.

### Back Pressure

The Check valves that have cracking pressure 5psig(0.34bar) and lower may not be able to return to the bubble-tight seal. This may require back pressure to press the seal to form a bubble-tight contact in addition to the spring force.

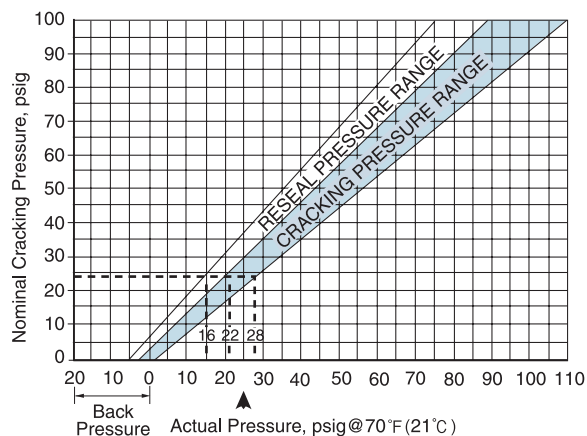

## Note

- When the check valve is not actuated for a period of time, it may require initially crack at higher than the above cracking pressure ranges.
- Check valves are designed for directional flow control only. Therefore HANSUN check valves should never be used as code Safety relief devices.

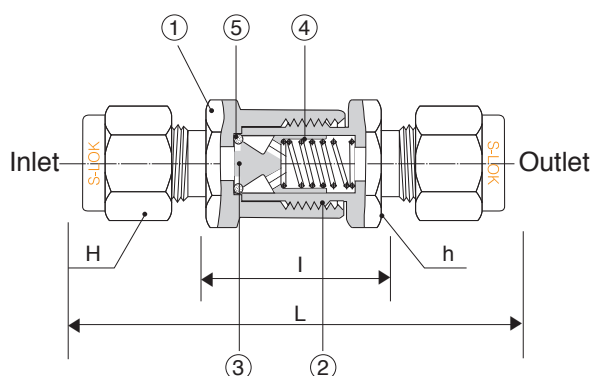

### Materials of Construction

Item	Description	Valve Body Materials	
		S316	Brass
1	Body	S316/A479,A276	Brass
2	Connector		Brass
3	Poppet	S316/A479,A276	Brass
4	Spring	S302	
5	O-ring	Viton	

\* Silicone-based Lubricant for poppet.

### Ordering Information and Dimensions

Basic Ordering Number	Orifice mm(inch)	Cv	End Connections Inlet/Outlet	Dimensions(mm)			
				h	H	L	I
SCV1	4.8 (0.19)	0.16	1/8" S-LOK	15.88(5/8)	11.11(7/16)	55.60(2.19)	25.00(0.98)
			1/8" Male NPT				
		1/8" Female NPT					
		1/4" S-LOK					
		6mm S-LOK					
		1/4" Male NPT 1/4" S-LOK					
SCV2	7.1 (0.28)	1.48	1/4" Female NPT	19.05(3/4)	17.46(11/16)	65.50(2.58)	27.10(1.07)
			3/8" S-LOK				
			10mm S-LOK				
			3/8" Male NPT				
SCV3	10.0 (0.39)	1.7	3/8" Female NPT	22.22(7/8)	22.22(7/8)	80.20(3.16)	36.20(1.43)
			1/2" S-LOK				
			12mm S-LOK				
			1/2" Male NPT				
SCV4	13.5 (0.53)	2.6	1/2" Female NPT	28.58(1-1/8)	25.40(1)	91.80(3.61)	48.10(1.89)
			5/8" S-LOK				
SCV5	16.0 (0.63)	5.2	3/4" S-LOK	31.75(1-1/4)	28.58(1-1/8)	110.70(4.35)	67.00(2.64)
			3/4" Male NPT				
			3/4" Female NPT				
SCV6	18.0 (0.71)	8.0	1" S-LOK	34.93(1-3/8)	38.1(1-1/2)	121.10(4.77)	68.40(2.69)
			1" Male NPT				
			1" Female NPT				

### Spring Cracking, Reseal and Back Pressure at @70°F(21°C)

Spring Nominal Cracking Pressure		Cracking Pressure Ranges				Reseal Pressure	
		Min. Pressure		Max. Pressure			
psig	bar	psig	bar	psig	bar	psig	bar
1/3	0.02	0	0	3	0.21	Up to 6 back pressure	0.41
1	0.07	0	0	4	0.28	Up to 5 back pressure	0.34
3	0.21	2	0.14	7	0.48	Up to 4 back pressure	0.28
10	0.69	7	0.48	15	1.03	3	0.21
25	1.72	20	1.38	30	2.07	17	1.17
50	3.45	40	2.76	60	4.14	35	2.41
75	5.17	60	4.14	90	6.2	53	3.65
100	6.89	80	5.51	120	8.27	70	4.82

### Pressure-Temperature Ratings

Ratings based on Viton O-ring in S316 stainless steel valves and NBR O-ring in brass valves.

Series	SCV1, SCV2, SCV3, SCV4 SCA1, SCA2, SCA3 SCP1, SCP2		SCV5, SCV6		S316 SCH Series	
	Working Pressure, psig (bar)					
Temperature °F(°C)	S316	Brass	S316	Brass	SCH1, SCH2	SCH3
	-10°F to 100°F (-23°C to 37°C)	3000(206)	3000(206)	2000(137)	1500(103)	6000(413)
200°F (93°C)	2575(177)	2600(179)	1715(118)	1300(89)	5160(355)	4290(295)
250°F (121°C)	2450(168)	2405(165)	1630(112)	1250(86)	4910(338)	4080(281)
300°F (148°C)	2325(160)	-	1545(106)	-	4660(321)	3875(267)
375°F (190°C)	2185(150)	-	1450(99.9)	-	4375(301)	3640(250)
400°F (204°C)	-	-	-	-	4280(294)	3560(245)

# SCP30 Series Compact One Piece Check Valves

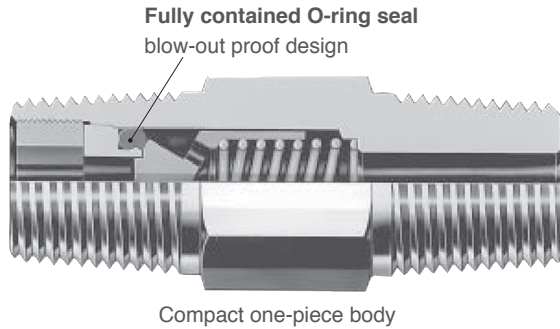

## Features

- Pressure rating up to 3,000psig (206bar)@70°F(21°C).
- Temperature rating up to 375°F(191°C) with Standard Viton O-ring.
- Choice of materials : Standard S316 and Brass.
- Cracking pressures include : 1/3, 1, 3, 10, 25, 50psi.
- Heat code traceability.
- Every valve is 100% factory tested for cracking and reseal.

## Spring Cracking, Reseal and Back Pressure at @70°F(21°C)

Spring Nominal Cracking Pressure		Applied Working Pressures—psig(bar)				Reseal Pressure	
		Min. Pressure		Max. Pressure			
psig	bar	psig	bar	psig	bar	psig	bar
1/3	0.02	0	0	3	0.21	up to 6	0.41
						Back pressure	
1	0.07	0	0	4	0.28	up to 5	0.34
						Back pressure	
10	0.69	7	0.48	15	1.03	3	0.21
25	1.72	20	1.38	30	2.07	17	1.17

## Materials of Construction

Item	Description	Valve Body Materials	
		S316	Brass
1	Body	S316 /A276,A479	Brass
2	Poppet		
3	Insert		
4	Locking Screw		
5	Spring	S302/A313	
6	O-ring	Viton	NBR

\* Silicone-based Lubricant for poppet.

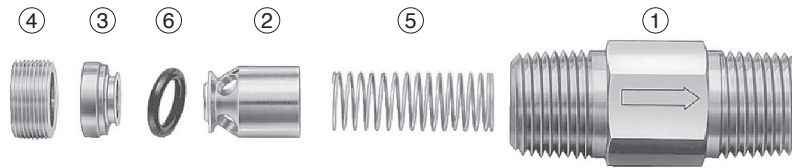

## Ordering Information and Dimensions

Basic Ordering Number		Cv	End Connections			Dimensions mm(inch)	
			Size	Inlet	Outlet	L	H
SCP1	M-4N	0.35	1/4"	Male NPT		41.1(1.62)	14.28(9/16)
	M-4R		Male ISO				
	F-4N		Female NPT		61.2(2.41)	19.05(3/4)	
	F-4R		Female ISO		64.5(2.54)		
	MF-4N		Male / female NPT		44.4(1.75)		
	FM-4N		Female / male NPT		58.2(2.29)		
SCP2	M-8N	1.20	1/2"	Male NPT		57.9(2.28)	22.22(7/8)
	F-8N		Female NPT		94.2(3.71)	26.98(1-1/16)	
	MF-8N		Male / female NPT		71.9(2.83)		

All dimensions shown are for reference only and are subject to change.

# SCA30 Series Adjustable One Piece Check Valves

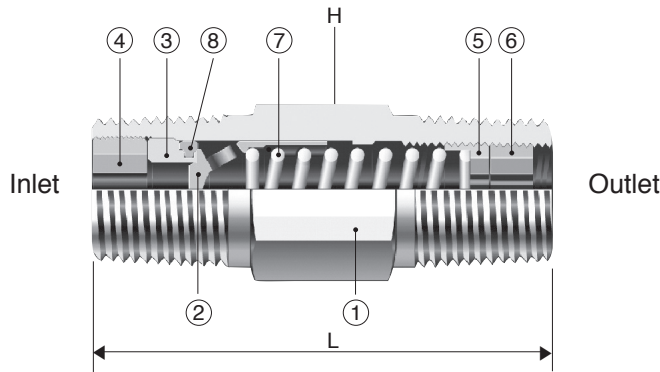

## Materials of Construction

Item	Description	Valve Body Materials	
		S316	Brass
1	Body	S316 /A276,A479	Brass
2	Poppet		
3	Insert		
4	Insert Lock Screw		
5	Adjusting Screw		
6	Locking Screw		
7	Spring	S302/A313	
8	O-ring	Viton	NBR

\* Silicone-based Lubricant for poppet.

## Features

- Pressure rating up to 3,000psig (206bar)@700°F(21°C).
- Temperature rating up to 375°F(191°C) with Standard Viton O-ring.
- Choice of materials : Standard S316 and Brass.
- Cracking pressure adjustable from 3 to 600psi (0.2 to 41.4 bar)
- Heat code traceability.
- Every valve is 100% factory tested for cracking and reseal.

## Spring Cracking Pressure Range Designator

Designator	Cracking Pressure	
	psi	bar
3	3 to 50	0.21 to 3.5
50	50 to 150	3.5 to 10.4
150	150 to 350	10.4 to 24.2
350	350 to 600	24.2 to 41.4

## Ordering Information and Dimensions

Basic Ordering Number		Cv	End Connections			Dimensions mm(inch)	
			Size	Inlet	Outlet	L	H
SCA1	F-4N	0.35	1/4"	Female NPT		75.7(2.98)	3 / 4
	M-4N		Male NPT		41.1(1.62)	9 / 16	
	M-4R		Male BSPT		41.1(1.62)	9 / 16	
SCA2	M-8N	1.20	1/2"	Male NPT		65.0(2.56)	7 / 8
	M-8R		Male BSPT		65.0(2.56)	7 / 8	

To order, add a cracking pressure range designator to the basic ordering number and then specify valve material designator.  
**Example : SCA1-M-4N-3-S6**

# SCH60 Series High Pressure Check Valves

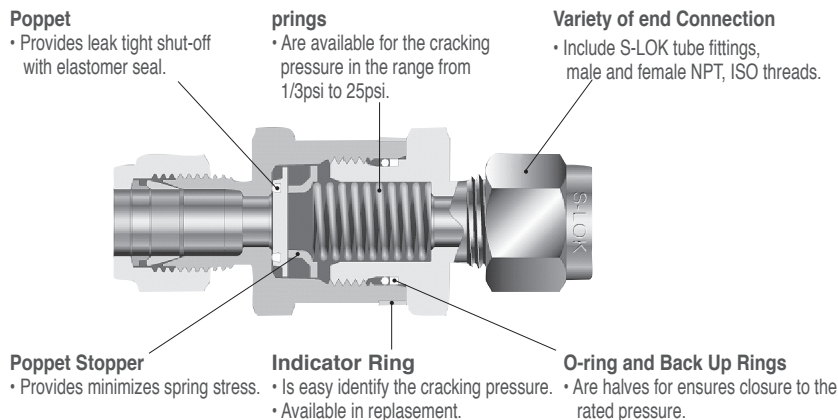

## Features

- Pressure rating up to 6000psi (413bar) @70°C(21°C).
- Temperature rating up to 375°F(191°C)with standard Viton O-ring.
- S316 Stainless steel body as standard.
- Suitable for gas and liquids.
- Cracking pressures include : 1/3, 1, 5, 10, 25psi.
- Heat code traceability.
- Every valve is 100% factory tested for cracking and reseal.

## Technical Data

Description	S316		
	SCH1	SCH2	SCH3
Series			
Flow Coefficient (Cv)	0.67	1.8	4.7
Working Pressure and Back Pressure @ 70°F(21°C)	6000psi(413bar)		5000psi(344bar)
Operating Temperature Range	Viton : -10°F to 375°F (-23°C to 190°C)		
Nominal Cracking Pressure	1/3, 1, 5, 10, 25psig		

## CNG / NGV Certifications

- CNG / NGV Check Valve Series with CNG / NGV Compatible HNBR O-ring are available with CNG / NGV Certifications

Certificates	ECE R110	ANSI NGV 3.1 - 2012	ISO 15500
Certificate No.	110R-010335	126842AUT16	126842MECH105
Classification	Class 0	Manual valve	Manual valve
Temperature	-40 to 120°C (-40 to 248°F)	-40 to 120°C (-40 to 248°F)	-40 to 120°C (-40 to 248°F)
Working Pressure	260 bar @ 120°C	248 bar @ 120°C	260 bar @ 120°C

## Materials of Construction

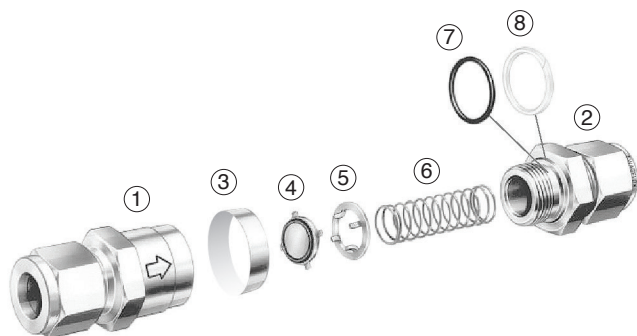

Item	Description	A479 Valve Body Materials	
		Material Grade	ASTM Specification
1	Body	S316	A479 or A276
2	Connector		
3	Indicator Ring		
4	Poppet	Viton-bonded S316	
5	Poppet Stopper	S316	
6	Spring	S302	A313
7	O-ring	Viton	
8	Back Up Ring	PTFE	

\* Silicone-based Lubricant for poppet. Wetted parts are listed in orange color.

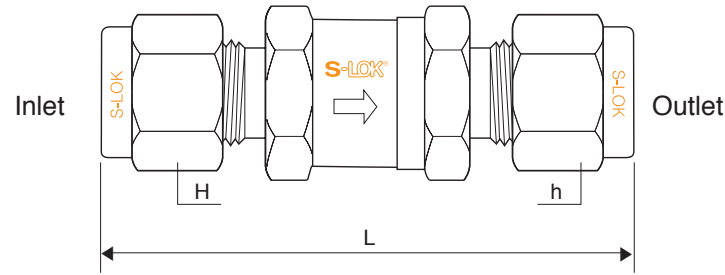

### Ordering Information and Dimensions

Basic Ordering Number	Orifice mm	Cv max.	End Connections			Pressure Rating psig(bar)	Dimensions mm(inch)					
			Size	Inlet	Outlet		L	H	h			
SCH1	4.8	0.67	1/8"	S-LOK		6000(413)	57.7(2.27)	(7/16)	(11/16)			
			1/4"	S-LOK			61.7(2.43)	(9/16)				
			6mm	S-LOK			54.1(2.13)	14.0				
			1/4"	Female NPT			45.5(1.79)					
			1/8"	Male NPT			55.1(2.17)					
			1/4"	Male NPT								
SCH2	7.8	1.8	3/8"	S-LOK		6000(413)	69.9(2.75)	(11/16)	(1)			
			1/2"	S-LOK			75.2(2.96)	(7/8)				
			8mm	S-LOK			68.6(2.70)	16				
			10mm	S-LOK			71.1(2.80)	19				
			12mm	S-LOK			75.2(2.96)	22				
			3/8"	Female NPT			64.8(2.55)					
			1/2"	Female NPT		4600(316)	77.0(3.03)	(1-1/16)				
			3/8"	Male NPT		6000(413)	59.9(2.36)	(1)				
			1/2"	Male NPT		69.3(2.73)						
			1/2"	Female ISO		4600(316)	83.6(3.29)	(1-1/16)				
			1/2"	Male ISO		6000(413)	69.3(2.73)	(1)				
			SCH3	15.0	4.7	3/4"	S-LOK		5000(344)	89.4(3.52)	(1-1/8)	(1-5/8)
						1"	S-LOK			98.6(3.88)	(1-1/2)	
						22mm	S-LOK			88.4(3.48)	32	
25mm	S-LOK					98.6(3.88)	40					
3/4"	Female NPT					4300(296)	82.0(3.23)					
1"	Female NPT					4100(282)	97.3(3.83)					
3/4"	Male NPT					5000(344)	83.6(3.29)					
1"	Male NPT					93.2(3.67)						
3/4"	Female ISO					4300(296)	82.0(3.23)					
1"	Female ISO					4100(282)	97.3(3.83)					
3/4"	Male ISO					5000(344)	85.1(3.35)					
1"	Male ISO					93.2(3.67)						

### Spring Cracking, Reseal and Back Pressure at @70°F(2°F)

Nominal Spring Cracking Pressure		Applied Working Pressures - psig(bar)				Reseal Pressure	
		Min. Pressure		Max. Pressure			
psi	bar	psi	bar	psi	bar	psi	bar
1/3	0.02	0	0	3	0.21	up to 6	0.41
						Back pressure	
1	0.07	0	0	4	0.28	up to 5	0.34
						Back pressure	
5	0.34	3	0.21	9	0.62	up to 2	0.14
						Back pressure	
10	0.69	7	0.48	15	1.03	3	0.21
25	1.72	20	1.38	30	2.07	17	1.17

## O-Ring Seal Materials

Material	Designator	Temperature Rating°C(°F)	Application
NBR	NB	-20°C to 105°C(-4°F to 221°F)	Petroleum-based hydraulic and lubricating oils, animals and vegetable oils, acetylene, alcohols, air, alkalis, fuel oils and many other media.
FKM (Viton)	VT	-23°C to 190°C(-10°F to 375°F)	High-quality compounds for high temperatures, Synthetic and hydraulic fluids; a wide range of chemicals, heavily oxidizing acids, suitable for vacuum.
EPDM	EP	-45°C to 148°C(-50°F to 300°F)	Chemical resistance : nonflammable hydraulic fluids (Skydrol, Pydraul, Lindol, Cellulube 150, phosphoric esters), pure aniline, fire extinguisher liquids (chlorobromo-methane), acid ;excellent resistance to hot water and steam.
FFKM	KA	-20°C to 275°C(-4°F to 527°F)	Superior compounds for high temperature and most chemicals. This compound combines the chemical properties of PTFE with the mechanical properties of Viton.

\* Viton is standard for S316 valves and NBR is standard for Brass valves.

### Sour Gas Service

- For sour gas application, materials for wetted components are selected according to NACE MR 0175.

Pressure Rating at 70°F(21°C)	SCH1 and SCH2 Series : 5000psig(344bar) SCH3 Series : 4700psig(323bar)
Temperature Rating	-50°F to 300°F(-45°C to 148°C)
Normal Cracking Pressure	1/3, 1, and 5psig(0.02, 0.07, 0.34bar)
End Connections	1/4, 3/8, 1/2, 3/4, and 1" S-LOK Tube Fittings
Material of Construction	Poppet stopper-S316 Spring-Alloy X750 Back up ring-PTFE Indicator ring-stainless steel

To order, add designator-SG as a suffix to the basic part number with cracking pressure.

**Example :** SCH1-S-4T-1/3-SG-S6

### Fluorocarbon-Free Service

- For system where, PTFE and fluorinated compounds can not be tolerated.

Pressure Rating at 70°C(21°C)	Same as standard product. See standard technical data.
Temperature Rating	-50°F to 300°F(-45°C to 148°C)
Normal Cracking Pressure	Same as standard product. See standard technical data.
End Connections	All end connection type and sizes. See table of dimensions.
Material of Construction	Body, Poppet, Poppet stopper-S316 Seals-ethylene propylene Spring-S302 Back up ring-PEEK Indicator Ring-stainless steel Lubricant-hydrocarbon based

To order, add designator-FF as a suffix to the basic part number with cracking pressure.

**Example :** SCH1-S-4T-1/3-OF-S6

### Testing

- Every valve is factory tested for cracking and reseal performance.

### Ordering Information

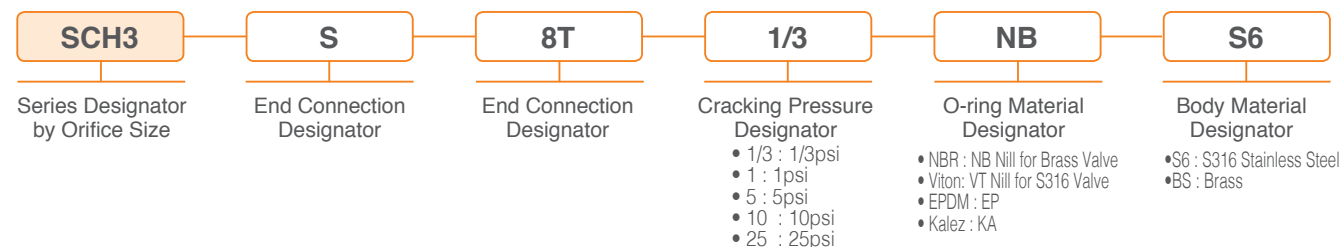

### \*CNG / NGV Service

- To order CNG / NGV Service, insert the designator "C" to the valve ordering number.
- O-Ring Material's HNBR standard.  
ex) SCHC3-S-8T-S6

### Safety in Valve Selection

- When selecting a valve, the total system design must be considered to ensure safe, trouble-free performance. Valve function, materials compatibility, adequate ratings, proper installation, operation, and maintenance are the responsibility of the system designer and user.

# SRV Series Relief Valves

## Low Pressure Relief Valve – SRV30

- Max. Working Pressure : 300 psi (21 bar)
- Cracking Pressure Range : 10 to 250psi(0.68 to 17.2bar)
- Orifice : 0.19 in. (4.8 mm)

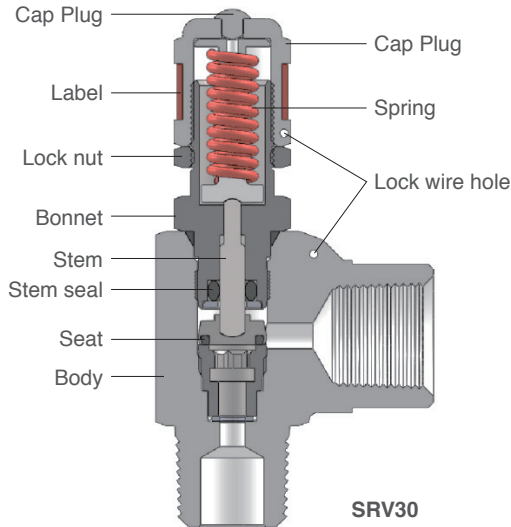

## High Pressure Relief Valve – SRV60

- Max. Working Pressure : 6000 psi (413 bar)
- Cracking Pressure Range : 50 to 6000 psi(3.4 to 413 bar)
- Orifice : 0.14 in. (3.6 mm)

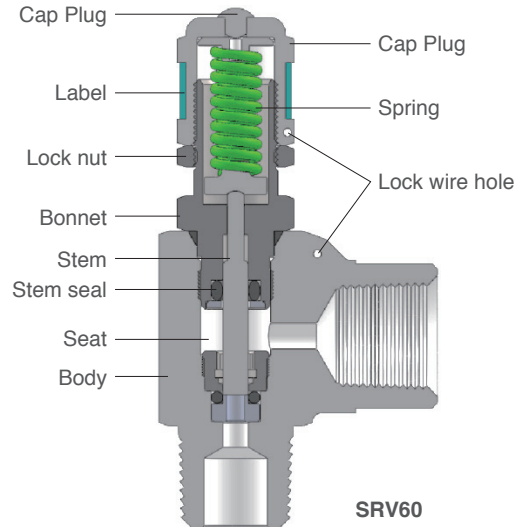

## Materials of Construction

Component	Material
Plug	Polypropylene
Cap	SS316 / A276
Bonnet	SS316 / A276
Stem	SS316 / A276
Poppet	SS316 / A276
Seal	FKM (Standard)
Body	SS316 / A182

## Applications

SRV series relief valves gradually open as pressure increases. SRV series relief valves have not certified to ASME or any other codes.

## Operation

SRV series relief valves open when the system pressure reaches the cracking pressure and close when the system pressure falls below the cracking pressure.

## Cracking Pressure

Cracking pressure range of each valve after initial relief. (whichever is greater)

- Below 60°F (15°C) : ± 6 psi (0.4bar) or ± 20 %
- 60 to 80°F (15 to 26°C) : ± 3 psi (0.2bar) or ± 5 %
- Above 80°F (26°C) : ± 6 psi (0.4bar) or ± 20 %

## Pressure – Temperature Ratings

Ratings are limited depending on the material. Valves are standard with FKM Seat and Seal.

Temperature, °F (°C)	Max. Cracking Pressure, psi (bar)	
	SRV30	SRV60
-40 (-40) to 70 (20)	250 (17.2)	6000 (413)
150 (65)	250 (17.2)	5580 (384)
200 (93)	250 (17.2)	5160 (355)
250 (121)	250 (17.2)	4910 (338)
275 (135)	250 (17.2)	-
300 (148)	250 (17.2)	-

Seal Material	Designator	Temperature, °F (°C)	
		SRV30	SRV60
FKM	VT	10 ~ 275 (-12 ~ 135)	25 ~ 250 (-4 ~ 121)
NBR	NBR	-10 ~ 300 (-23 ~ 148)	0 ~ 250 (-17 ~ 121)
EPDM	EP	-40 ~ 300 (-40 ~ 148)	30 ~ 250 (-1 ~ 121)

## Ordering Information and Dimension

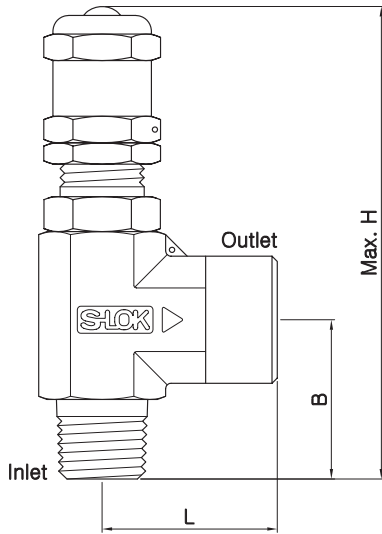

### SRV Series Spring

Designator	Cracking Pressure Range		Color
	psi	bar	
SRV30 series spring			
L	10 to 250	0.68 to 17.2	Red
SRV60 series spring			
A	50 to 350	3.4 to 24.1	White
B	350 to 750	24.1 to 51.7	Blue
C	750 to 1500	51.7 to 103	Clear
D	1500 to 2250	103 to 155	Black
E	2250 to 3000	155 to 206	Green
F	3000 to 4000	206 to 275	Yellow
G	4000 to 5000	275 to 344	Brown
H	5000 to 6000	344 to 413	Orange

Basic Ordering NO.	End Connection		Dimensions mm (in.)			
	Inlet / Outlet	Size	H	B	L	
SRV30 or SRV60	S-4T	S-LOK	1/4 "	100 (3.93)	37 (1.45)	39
	S-8T	S-LOK	1/2 "	105 (4.13)	44 (1.73)	42 (1.65)
	S-6M	S-LOK	6mm	100 (3.93)	38 (1.49)	40 (1.57)
	S-8M	S-LOK	8mm	100 (3.93)	38 (1.49)	40 (1.57)
	S-12M	S-LOK	12mm	105 (4.13)	44 (1.73)	42 (1.65)
	MS-8N8T	Male NPT / S-LOK	1/2 "	98 (3.85)	36 (1.41)	42 (1.65)
	MS-8N12M	Male NPT / S-LOK	1/2 " / 12mm	98 (3.85)	36 (1.41)	42 (1.65)
	MF-4N	Male / Female NPT	1/4 "	94 (3.70)	32 (1.25)	30 (1.18)
	MF-6N	Male / Female NPT	3/8 "	94 (3.70)	32 (1.25)	35 (1.37)
	MF-8N	Male / Female NPT	1/2 "	98 (3.85)	36 (1.41)	38 (1.49)

\* Dimensions are for reference only and are subject to change. Dimensions shown with S-LOK nuts finger-tight position.

### Relief Valve - SRV Series

• The valve contains a spring, and the set pressure must be adjusted. It is possible to supply after setting pressure to desired pressure.

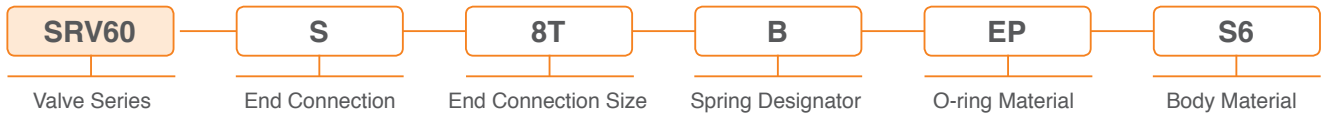

### Spring Kit

• Spring kits include spring, label, lock wire with lead seal and replacement instruction

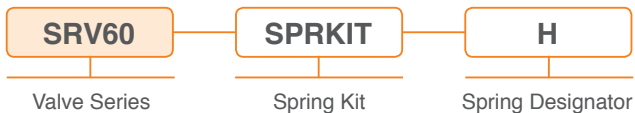

### Seal Kit

• Seal kits include poppet, bonnet assembly and replacement instruction



# SEV Series Excess Flow Valves

## ⚡ Operation

The spring loaded poppet remains in the open position during normal system operation. Should an downstream pressure drops the poppet rapidly move to the tripped position, and the downstream line is closed or repaired, when the system pressure equalizes through the bleed vent, the spring automatically resets the poppet to the open position.

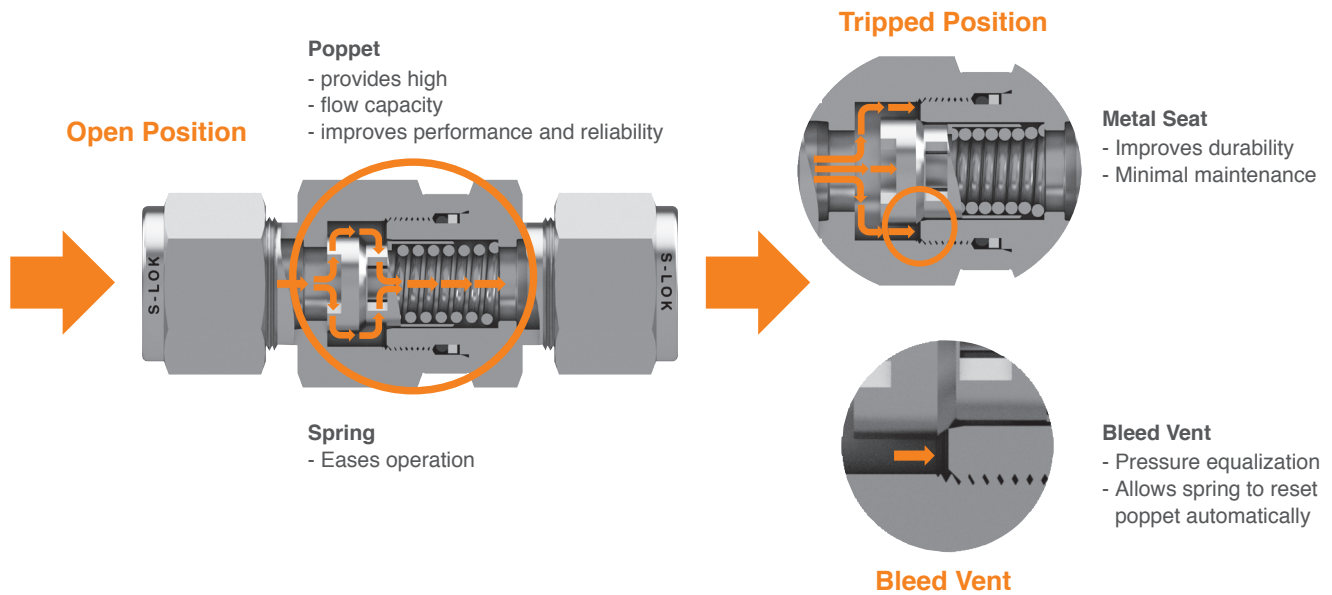

## ⚡ Materials of construction

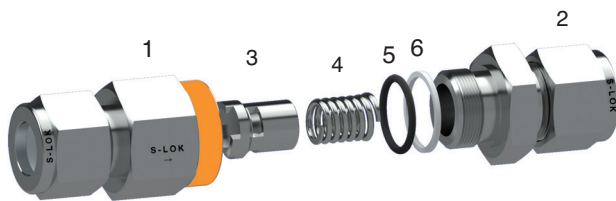

No.	Description	Material	Q'ty
1	Body	S316	1
2	End Connector	S316	1
3	Poppet	S316	1
4	Spring	S302	1
5	O-ring	FKM	1
6	Backup ring	PTFE	1

## ⚡ Pressure - Temperature Ratings

Temperature, °F (°C)	Working Pressure, psig(bar)
10 to 100 (-23 to 37)	6000 (413)
200 (93)	5160 (355)
250 (121)	4910 (338)
300 (148)	4660 (321)
400 (204)	4280 (294)

## ⚡ Optional O - Ring Materials

O-Ring Material	Designator	Temperature °F (°C)
FKM	NIL	-10 to 400 (-23 to 204)
NBR	NBR	-4 to 221 (-20 to 105)
EPDM	EP	-50 to 300 (-45 to 148)
FFKM	FFKM	-10 to 400 (-23 to 204)

### Flow Rate at 70°F(20°C)

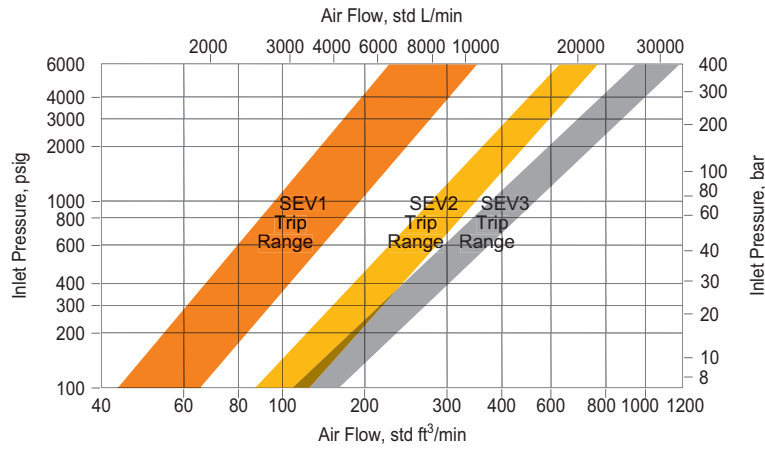

### Water

Series	Cv	Trip Range L / min (U.S. gal/min)
SEV1	0.5	14.7 to 21.9 (3.9 to 5.8)
SEV2	1.1	31.0 to 37.8 (8.2 to 10.0)
SEV3	1.1	42.3 to 56.3 (11.2 to 14.9)

### Ordering Information and Dimensions

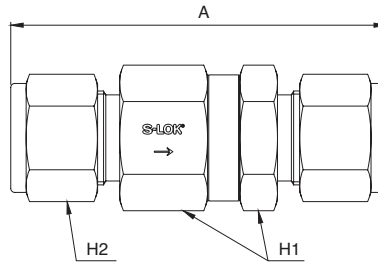

Basic Ordering Number	End Connection		Dimensions mm (in.)		
	Inlet	Outlet	A	H <sub>1</sub>	H <sub>2</sub>
SEV1	S-4T	1/4" S-LOK	61.9 (2.44)	17.46 (11/16)	14.28 (9/16)
	S-6M	6mm S-LOK	61.8 (2.43)		14
	M-2N	1/8" Male NPT	46.6 (1.83)		-
	M-4N	1/4" Male NPT	46.6 (1.83)		-
	F-2N	1/8" Female NPT	54.6 (2.15)		-
	F-4N	1/4" Female NPT	54.6 (2.15)		-
	MF-4N	1/4" Male NPT	1/4" Female NPT		54.6 (2.15)
SEV2	S-6T	3/8" S-LOK	70.2 (2.76)	25.4 (1)	17.46 (11/16)
	S-8M	8mm S-LOK	68.9 (2.71)		16
	S-10M	10mm S-LOK	70.5 (2.77)		19
	M-6N	3/8" Male NPT	61.8 (2.43)		-
	F-6N	3/8" Female NPT	61.8 (2.43)		-
	MF-6N	3/8" Male NPT	3/8" Female NPT		61.8 (2.43)
SEV3	S-8T	1/2" S-LOK	75.7 (2.98)	25.4 (1)	22.22 (7/8)
	S-12M	12mm S-LOK	75.8 (2.98)		22
	M-8N	1/2" Male NPT	69.8 (2.74)	27	-
	F-8N	1/2" Female NPT	69.8 (2.74)		-
	MF-8N	1/2" Male NPT	1/2" Female NPT		69.8 (2.74)

