



# ***Systematic fitting selection***

---

**Introduction**

**Product selection**

Ultimate target is to find the “best solution”. This optimum solution provides high system reliability, easy assembly characteristics, low maintenance effort and avoids the use of exotic components.

This “best solution” is not the ultimately achievable technology, but an adequate solution which fulfils the requirements of the individual application with minimum system cost.

The “best solution” looks different depending on the specific criteria of the given application.

**Dry Technology**

Modern TFDE fittings are designed for high reliability, easy assembly and lowest total cost performance.

These products are marked *Dry Technology* and indicated grey in selection charts.

Parker recommends to select only *Dry Technology* products for all new designs.

**Design criteria for fitting selection**

**Step 1**

First clarify all design criteria for the given application or project.

**Step 2**

Then determine the “best solution” product. Use selection charts on following pages.

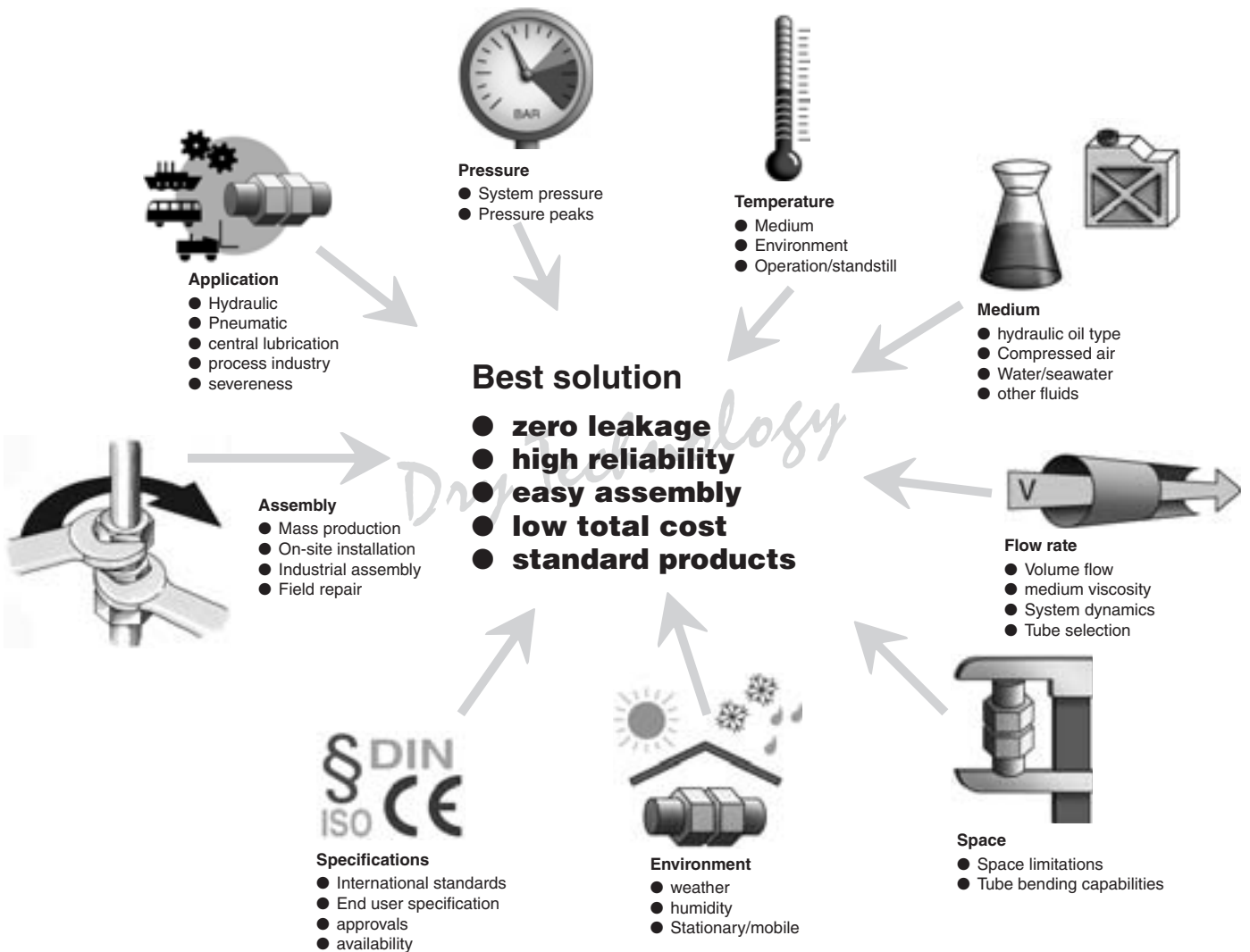

**Material selection: Fitting material**



**Environment**

- select fitting material with suitable corrosion resistance



**Medium**

- select compatible fitting material

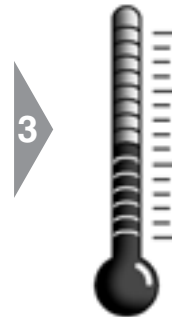

**Temperature**

- check suitability

Tube Material: Fitting material:	Steel, zinc-plated Steel, zinc-plated	Stainless steel Stainless steel	Copper Brass	Stainless steel Steel	Plastic Steel, Stainless steel, Brass
<b>Performance characteristics:</b>					
Pressure capability	Excellent	Excellent	Good	Excellent	Low
External temperature capability	Very good	Excellent	Very good	Very good	Depending on tube and material
Corrosion resistance	Good	Excellent	Very good	Good	Good
Internal media compatibility	Good	Excellent	Very good	Good	Good
<b>Current use</b>	Standard material combination for general use in hydraulic systems	Standard material combination for use with aggressive media or application in corrosive environments	Low to medium pressure applications in corrosive environment Use with compressed air (condensed water) or slightly corrosive media (water)	Special material combination for mildly corrosive environments	Special material combination for low pressure applications
<b>Typical applications:</b>	Machine tools, Mobile construction equipment	Shipbuilding, Offshore exploration, Process engineering, Paper machines, costal installations	Central lubrication systems, Pneumatics, cooling water tubes	Some airbrake systems in railway industry, wet machining area on machine tools	Pneumatic systems on machine tools, central lubrication and airbrakes in truck industry

## Material selection: Sealing material



### Medium

- select compatible fitting material

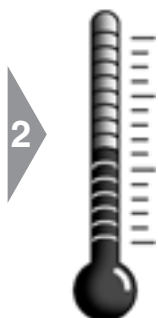

### Temperature

- check suitability

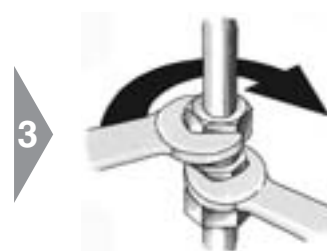

### Assembly

- Prefer elastomer sealing for easy assembly and economic service

Sealing technology	metal-to-metal	nitrile rubber (NBR)-Elastomer	Fluorcarbon (FKM)-Elastomer
<b>Performance characteristics:</b>			
High pressure capability	Good	Excellent	Excellent
Low temperature capability	Excellent	Very good	Good
High temperature capability	Excellent	Good	Very Good
Media compability	Excellent	Good	Very Good
Long term reliability	Good	Excellent	Excellent
<b>Assembly characteristics:</b>			
Ease of initial assembly	Good	Excellent	Excellent
Repeated assembly	Good	Excellent	Excellent
Replacement of seal	Not possible	Easy	Easy
<b>Current use</b>	Suitable for aggressive media respectively for very low or very high temperatures	General use in – hydraulic – pneumatic – lubrication – airbrake systems	Hydraulic and pneumatic systems with high operating temperature process engineering: some aggressive media
<b>Typical applications:</b>	Process engineering Agricultural Equipment	Machine tools Hydraulic presses Mobile construction equipment	Steelmill equipment Casting machines

**LL/L/S Series selection for EO fittings**



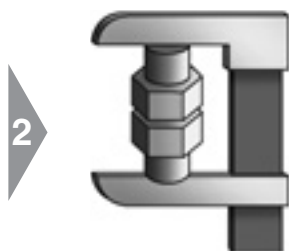

**Pressure**  
 ● select series with adequate pressure performance



**Space**  
 ● select series according to available space



**Specification**  
 ● prefer L or S series for best availability

			
Series	<b>LL</b>	<b>L</b>	<b>S</b>
Example of order code	G06ZLLCF	G06ZLCF	G06ZSCF
Design	Very light	Light	Heavy
Performance PN	100 bar	160–500 bar	315–800 bar
Suitability for heavy duty applications	Good	Good	Excellent
Tube dimension (mm)	4, 6, 8, 10, 12	6, 8, 10, 12, 15, 18, 22, 28, 35, 42	6, 8, 10, 12, 14, 16, 20, 25, 30, 38
Assembly Tightening effort Space requirement	Very low Very low	Normal Low	High High
<b>Current use</b>	Very light design for space-limited assemblies in low to medium pressure applications	medium to high pressure fitting for general use in hydraulic and pneumatic systems	Rigid design for use in heavy-duty applications
<b>Typical applications:</b>	Central lubrication Airbrake systems fuel lines oil/gas stoves micro hydraulics	machine tools agricultural vehicles	hydraulic presses plastic injection molding steel mills shipbuilding Mobile construction equipment

## Tube end selection



### Pressure

- select connection type with adequate pressure performance
- prefer elastomeric seal for most reliable sealing performance

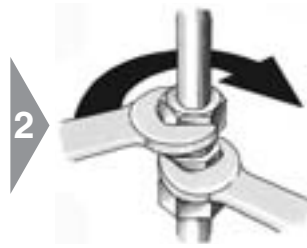

### Assembly

- select product with adequate assembly process

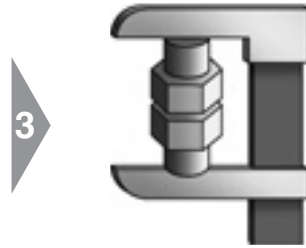

### Space

- select most suitable product



### Specification

- fitting type according to project specification

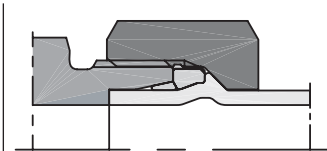
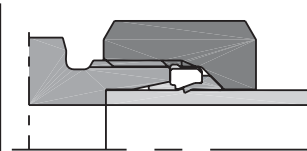
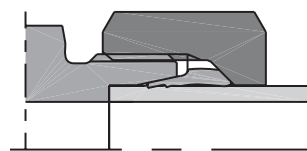

Type	EO PSR/DPR Metal seal bite type	EO-2 Soft seal bite type	EO2-Form Tube forming
Sealing method	Metal seal	Elastomeric seal	Elastomeric seal
International Standard	ISO 8434-1	ISO 8434-1	ISO 8434-1/4
National Standards	DIN EN ISO 8434-1 (old: DIN 2353/DIN 3861)	DIN EN ISO 8434-1 (old: DIN 2353/DIN 3861)	DIN EN ISO 8434-1 (old: DIN 3861)
Tube compatibility	Metal and plastic tube (steel, stainless steel, copper, aluminium, polyamide ...)		Steel, stainless steel, copper alloy
Available sizes (Tube O.D.)	4LL-12LL 6L-42L 6S-38S	4LL-6LL 6L-42L 6S-38S	Tube O.D. 6 to 42 mm 6L-42L 6S-38S
Performance seal reliability	Very good	Excellent	Excellent
Assembly Tube preparation Installation Field repair	Excellent Good Very good	Excellent Very good Excellent	Good Excellent Use EO2
Space requirements	Excellent	Excellent	Good
<b>Current use</b>	Most popular fitting for metric tube		Heavy duty alternative to EO/EO2 and EO weld nipple
	Traditional bite type fitting new designs	Global popularity for all	
<b>Typical applications</b>	General use in hydraulic, pneumatic, lubrication and coupling systems		General use in high pressure applications
	Agricultural equipment Process engineering	Hydraulic presses Injection Molding Mobile equipment Heavy machinery Ship building	

**Tube end selection**



**Pressure**

- select connection type with adequate pressure
- prefer elastomeric seal for most reliable sealing performance



**Assembly**

- select product with adequate assembly process

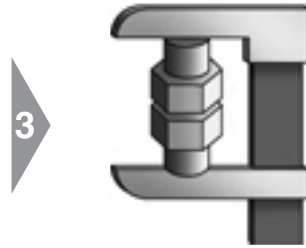

**Space**

- select most suitable product



**Specification**

- fitting type according to project specification

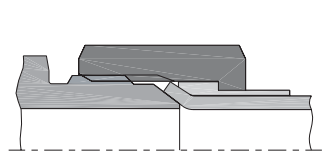
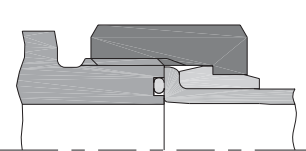
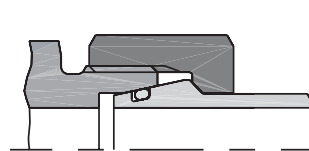

Type	<b>EO SKA</b> Weld nipple	<b>O-Lok®</b> O-Ring Face Seal (ORFS)	<b>Triple-Lok®</b> 37° Flare
Sealing method	Elastomeric seal	Elastomeric seal	Metal seal
International Standard	ISO 8434-1/4	ISO 8434-3	ISO 8434-2
National Standards	DIN EN ISO 8434-1/-4 (old: DIN 3865)	SAE J1453/J516	SAE J514/J516
Tube compatibility	Weldable steel and stainless steel	Metal tube (steel, stainless steel, copper, aluminium)	
Available sizes (Tube O.D.)	6L-42L 6S-38S	Tube O.D. 6 to 50 mm Tube O.D. 1/4" to 2"	Tube O.D. 6 to 42 mm Tube O.D. 1/8" to 2"
Performance seal reliability	Excellent	Excellent	Very good
Assembly Tube preparation Installation Field repair	Difficult Excellent Difficult	Good Excellent Use braze adapter	Good Excellent Hand flaring
Space requirements	Very good	Good	Very good
<b>Current use</b>	Limited use in Northern Europe and Asia	Heavy duty <i>Dry Technology</i> alternative to Triple-Lok® Most popular fitting for inch tube (metric tube on request) USA, Europe, gaining acceptance in Asia.	Worldwide
<b>Typical applications</b>	Limited use for special applications Heavy machinery Ship building power plants	General use in high pressure-hydraulic Mobile equipment Injection Molding Hydraulic presses Heavy machinery Ship building	General use in hydraulic, pneumatic, lubrication and coupling systems Agricultural equipment* Process engineering

## Flange type selection

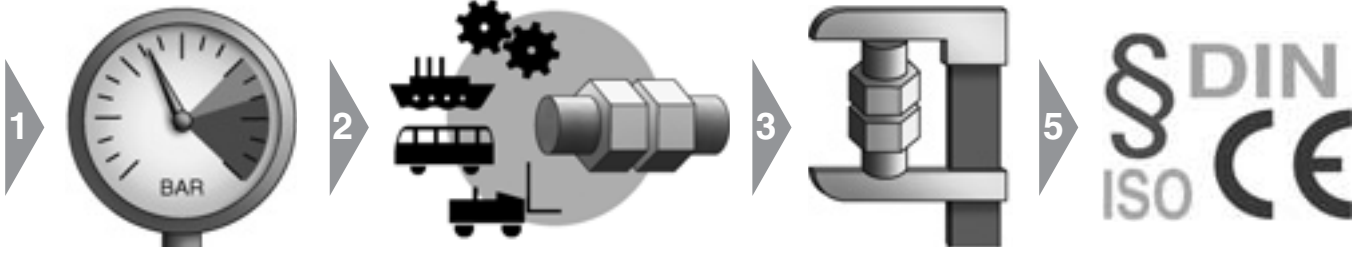

### Pressure

- select flange type connection with adequate pressure performance

### Application

- select suitable flange type for specific application

### Space

- select flange type according to available space

### Specification

- select flange type according to project specification

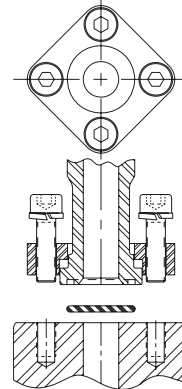
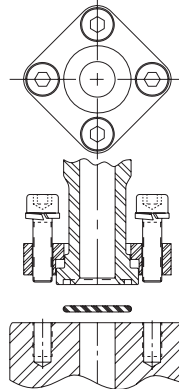
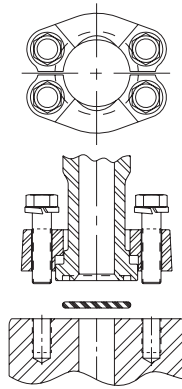

Flange type	Four screw split flange	Four screw one piece square flange	Cetop flange
Sealing method	Elastomeric seal	Elastomeric seal	Elastomeric seal
International standard	ISO 6162-1/-2	ISO 6164 (1994)	
National standard	DIN ISO 6162-1/-2/SAE J518	–	former Cetop
Tube compatibility	Combines weld and thread connections	Weld connection	Weld connection
Available sizes (Tube O.D.)	1/2" up to 5"	3/8" up to 4"	3/8" up to 4"
Performance seal reliability	Excellent	Excellent	Excellent
Assembly Tube preparation Installation Field repair	Good Excellent Good	Difficult Excellent Difficult	Difficult Excellent Difficult
Space requirements	Low	Low	Low
Used screws	metric screws according to: – DIN 912-8.8 (ISO 4762-8.8) or – DIN 912-10.9 (ISO 4762-10.9) UNC screws according to ASA B 18.3	metric screws according to: – DIN 912-8.8 (ISO 4762-8.8) or – DIN 912-10.9 (ISO 4762-10.9)	metric screws according to: – DIN 912-8.8 (ISO 4762-8.8) or – DIN 912-10.9 (ISO 4762-10.9)
Current use	Widely used throughout the world	Mainly used in Germany	Mainly used in Europe
Typical applications	Agriculture Hydraulic Offshore Ship building Cranes	Agriculture Hydraulic Offshore Ship building Cranes	Agriculture Hydraulic Offshore Ship building Cranes

Port/Stud selection



**Pressure**  
 ● select connection with adequate pressure performance

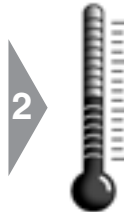

**Temperature**  
 ● Use elastomeric seal when suitable

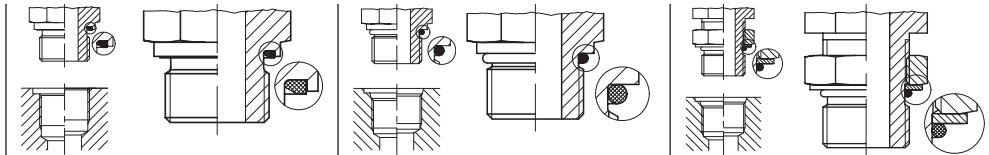

Port end selection:	Male stud with EOLASTIC-seal	Male stud with O-Ring seal	Male stud adjustable with O-Ring seal
<b>Port description metric</b>	<b>Male stud with EOLASTIC-sealing</b>	<b>Male stud with O-ring sealing</b>	<b>Male stud adjustable with O-ring sealing</b>
Thread	Metric	Metric	Metric
Example of order code EO =	GE12ZLMEDCF	GEO12ZLMCF	VEE12ZSMORCF
Example of order code Triple-Lok® =	8M16F82EDMXS	8M16F87OMXS;	8M18V87OMXS
Example of order code O-Lok® =	8M16F82EDMLOS	8M16F87OMLOS	8M18V87OMLOS
Thread standard (Example)	M 16×1.5 ISO 261; ISO 724; DIN 13-T5-T7	M 16×1.5 ISO 261; ISO 724; DIN 13-T5-T7	M 18×1.5 ISO 261; ISO 724; DIN 13-T5-T7
Male stud standard	DIN EN ISO 9974-2 (old: DIN 3852 T11, type E)	DIN ISO 6149-2/3 (old: DIN 3852 T3, type F)	DIN ISO 6149-2/3
Port tapping standard	DIN EN ISO 9974-1 (old: DIN 3852 T1, type X, Y)	DIN ISO 6149-1 (old: DIN 3852 T3, type W)	DIN ISO 6149-1 (old: DIN 3852 T3, type W)
Performance characteristics – pressure capacity – sealing characteristics – additional sealant required	Very high Excellent No	Very high Excellent No	High Very good No
<b>Current use</b>	Solid, soft sealing male studs. Known worldwide. Well suitable for using with gas and high pressure hydraulics.	New safe sealing system for all areas of application, especially suitable for high pressure hydraulics. Standard sealing for the future. Identifying marking for metric version is a groove at the collar.	New safe adjustable sealing system for all areas of application, especially suitable for high pressure hydraulics. Standard sealing for the future.
	Well suitable for soften for counter material (e.g. housing of Al-alloy).		
<b>Port description inch</b>	<b>Male stud with EOLASTIC-sealing</b>	<b>Male stud with O-ring sealing</b>	Male stud adjustable with O-ring sealing
Thread	BSP	UN/UNF threads	UN/UNF threads
Example of order code EO =	GE12ZLR1/4EDCF	GE12ZL3/4UNFCF	VEE12ZL3/4UNFCF
Example of order code Triple-Lok® =	8-4F42EDMXS	8F50XS	8V50MXS
Example of order code O-Lok® =	8-4F42EDMLOS	8F50MLOS	8V50MLOS
Thread standard (Example)	G 1/4 A DIN/ISO 228-T1 BS 2779	GB: 1/4 BSPP Japan: 1/4 PF	3/4-16 UNF ISO 725/ANSI B1.1-1974
Male stud standard	DIN 3852 T11, type E ISO 1179-2	ISO 11926-2/3	ISO 11926-2/3
Port tapping standard	DIN 3852 T2, type X, Y ISO 1179-1	ISO 11926-1	ISO 11926-1
Performance characteristics – pressure capacity – sealing characteristics – additional sealant required	Very high Excellent No	Very high Excellent No	High Very good No
<b>Current use</b>	Solid, soft sealing male studs. Known worldwide. Well suitable for soften counter material (e.g. housing of Al-alloy). Well suitable for using with gas and high pressure hydraulics.	Predecessor of metric sealing system. Often used in USA. Well suitable for soften counter material (e.g. housing of Al-alloy). Well suitable for using with gas.	Predecessor of metric adjustable sealingsystem. Often used in USA. Well suitable for soften counter material (e.g. housing of Al-alloy).

## Port/Stud selection

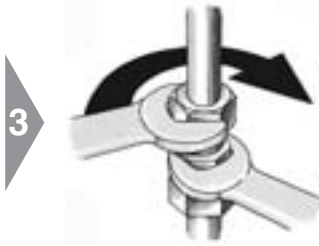

### Assembly

- prefer O-Ring/ ED-seal for easy assembly and economic service
- avoid tapered threads



### Application

- select standard connection for specific application

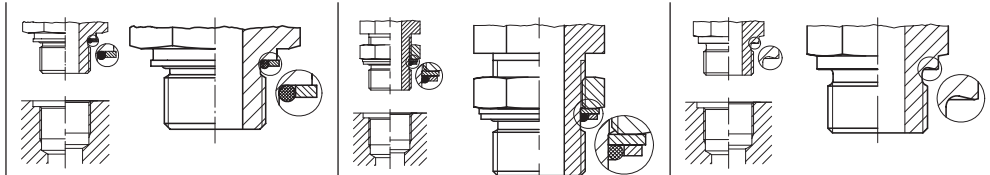

Port end selection:	Male stud O-ring retainer ring	Male stud adjustable with O-ring seal and Backup washer	Male stud with sealing by cutting face
<b>Port description metric</b>	<b>Male stud adjustable with O-ring sealing</b>	<b>Male stud adjustable with O-ring sealing</b>	<b>Male stud with sealing by cutting face</b>
Thread	Metric	Metric	Metric
Example of order code EO =	–	VEE12ZSMCF	GE12LMCF
Example of order code Triple-Lok® =	8M16F8OMXS	8M18V8OMXS	–
Example of order code O-Lok® =	–	8M18V8OMLOS	–
Thread standard (Example)	M 18×1.5 ISO 261; ISO 724; DIN 13-T5-T7	M 18×1.5 ISO 261; ISO 724; DIN 13-T5-T7	M 16×1.5 ISO 261; ISO 724; DIN 13-T5-T7
Male stud standard	–	–	DIN EN ISO 9974-3 (old: DIN 3852 T3, type B)
Port tapping standard	DIN EN ISO 9974-1 (old: DIN 3852 T1, type X, Y)	DIN EN ISO 9974-1 (old: DIN 3852 T1, type X, Y)	DIN EN ISO 9974-1 (old: DIN 3852 T1, type X, Y)
Performance characteristics – pressure capacity – sealing characteristics – additional sealant required	Medium Good No	Medium to high Good No	High Medium to good No
<b>Current use</b>		New adjustable sealing system for all areas of application.	Suitable for aggressive media respectively for very low or high temperatures, where elastic sealing cannot be used.
	Used in Europe and Asia-Pacific areas.		
	Well suitable for soften counter material/e. g. housing of Al-alloy.		
<b>Port description inch</b>	<b>Male stud adjustable with O-ring sealing</b>	<b>Male stud adjustable with O-ring sealing and Backup washer</b>	<b>Male stud with sealing by cutting face</b>
Thread	BSP	BSP	BSP
Example of order code EO =	–	VEE12ZLRCF	GE12LR1/4CF
Example of order code Triple-Lok® =	8-F40MXS	8V40MXS	–
Example of order code O-Lok® =	–	8V40MLOS	–
Thread standard (Example)	G 3/8 A DIN/ISO 228-T1	G 3/8 A DIN/ISO 228-T1	G 1/4 A DIN/ISO 228-T1, BS 2779
Further standards	GB: 1/4 BSPP, Japan: 1/4 PF	GB: 1/4 BSPP, Japan: 1/4 PF	GB: 1/4 BSPP, Japan: 1/4 PF
Male stud standard	ISO 1179-3	ISO 1179-3	DIN 3852 T2, type B, ISO 1179-4
Port tapping standard	ISO 1179-1; DIN 3852 T2, type X, Y	ISO 1179-1; DIN 3852 T2, type X, Y	DIN 3852 T2, type X, Y, ISO 1179-1
Performance characteristics – pressure capacity – sealing characteristics – additional sealant required	High Very good No	Medium to high Good No	High Medium to good No
<b>Current use</b>	Used in Europe and Asia-pacific areas.	Solid, soft sealing male studs. Known worldwide.	Suitable for aggressive media respectively for very low or high temperatures, where elastic sealing cannot be used.
	Well suitable for soften counter material (e.g. housing of Al-alloy).		

Port/Stud selection



**Specification**

- select connection type according to project specification
- prefer international standards
- select ISO 6149 for new designs

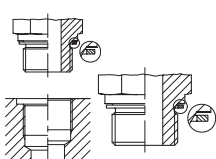
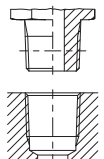
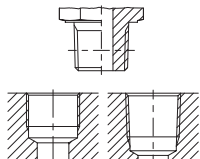
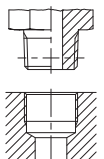
Port end selection:	 Male stud with sealing by metal sealing ring	 Male stud with sealing by taper thread	 Male stud with sealing by taper thread	 Male stud with sealing by taper thread
<b>Port description metric</b>	<b>Male stud with sealing by metal sealing ring</b>	<b>Male stud with sealing by taper thread</b>	–	<b>Male stud with sealing by taper thread</b>
Thread	Metric	NPT	–	Metric
Example of order code EO =	GE12LMACF	GE12L1/2NPTCF	–	GE08LLMCF
Example of order code Triple-Lok® =	–	8-8FMTXSS	–	–
Example of order code O-Lok® =	–	8-8FLOSS	–	–
Thread standard (Example)	M 16×1.5; ISO 261; ISO 724; DIN 13-T5-T7	1/2-14 NPT ANSI B1.20.1-1983	–	M 10×1.0 tap. DIN 158
Male stud standard	DIN 3852 T1, type A DIN 7603 (Sealing washer)	ANSI B1.20.1-1983	–	DIN 3852 T1, type C
Port tapping standard	DIN EN ISO 9974-1 (old: DIN 3852 T1, type X, Y)	ANSI B1.20.1-1983	–	DIN 3859 T1, type Z (parallel)
Performance characteristics – pressure capacity – sealing characteristics – additional sealant required	Low Medium No	Very high Medium Yes	–	Low Medium Yes
<b>Current use</b>	Partly used for pneumatics and gas applications.	Mainly used in North America. Some used in rest of the world. Male studs and port tapping are tapered. Sealing only achieved with fluid or plastic sealing material.	–	Only for low requirements due to parallel port. Leakfree performance is only achieved with fluid or plastic thread sealing material. Mainly used in Germany.
<b>Port description inch</b>	<b>Male stud with sealing by metal sealing ring</b>	<b>Male stud with sealing by taper thread</b>	<b>Male stud with sealing by taper thread</b>	<b>Male stud with sealing by taper thread</b>
Thread	BSPP	NPTF	BSPT	Shorter BSPT
Example of order code EO =	GE12LR1/4ACF	–	GE12LR1/2KLCF**)	GE12LR1/4KEGCF
Example of order code Triple-Lok® =	–	12FMTXS	8-8F3MXXS	–
Example of order code O-Lok® =	–	12FLOS	–	–
Thread standard (Example)	G 1/4 A DIN/ISO 228-T1 BS 2779	3/4-14 NPTF ANSI B1.20.3-1983	R 1/2 ISO 7; DIN 2999-1 BS 21	R 1/4 (short) DIN 3858
Further standards	GB: 1/4 BSPP; Japan: 1/4 PF	–	GB: 1/4 BSPT; Japan: 1/4 PT	–
Male stud standard	DIN 3852 T2, type A DIN 7603 (Sealing washer)	SAEJ 476a	ISO 7; DIN 2999-1	DIN 3852 T2, type C
Port tapping standard	DIN 3852 T2, type X, Y ISO 1179-1	SAEJ 476a ANSI B1.20.3	ISO 7/1-Rp/Rc; DIN 2999-Rc BS 21-Rp/Rc; Japan PT-Port	DIN 3852 T2, type Z (parallel)
Performance characteristics – pressure capacity – sealing characteristics – additional sealant required	Low Medium No	Very high Medium Recommended	Medium Medium Yes	Low Medium Yes
<b>Current use</b>	More and more unimportant. Partly used for pneumatics.	Mainly used in North America. Male studs and port tapping are tapered. The same as NPT except that closer tolerances are held to assure metal to metal contact (dryseal thread).	Mainly used in GB and Asia-Pacific areas. Male studs are tapered. Ports are mainly tapered, but can be parallel also. Leakfree performance is only achieved with fluid or plastic thread sealing material. <b>***)Male stud end not included in the catalogue!</b>	Only for low requirements due to parallel port. Leakfree performance is only achieved with fluid or plastic thread sealing material. Mainly used in Germany. <b>Not to be used for BSPT ports and PT ports (Japanese Standard) due to poor thread engagement!</b>

## Orientable Fitting Selection



1

### Pressure

- pre-select orientable fitting with sufficient pressure performance
- prefer elastomeric seal for most reliable sealing performance

2



### Flow Rate

- select optimum solution for best flow rate and available space

Type	90° tube bend and male stud		Swivel Elbow		Adjustable Elbow
EO:	GE12LMCF	GE12ZLMEDCF	EVW	EW	WEE
Triple-Lok®:	FMTX, F3MX	F82EDMX	–	F82EDMX+C6MX	C8OMX
O-Lok®:	–	F82EDMLO	–	F82EDMLO+C6MLO	C8OMLO
Design	DPR/PSR Triple-Lok® Metal sealed port	EO-2 O-Lok® Elastomeric sealed port	Adjustable elbow with preassembled EO-DPR/PSR	Adjustable elbow with swivel nut connection	Adjustable Elbow with adjustable male stud
Sealing method	Metal	Elastomeric	Metal	Elastomeric	Elastomeric
Performance pressure Seal reliability Flow characteristics Compactness	Good Good Excellent Bulky	Excellent Excellent Excellent Bulky	Good Good Very good Good	Excellent Excellent Very good Good	Very good Good Very good Very good
Assembly/Installation Field repair	Very good Good	Excellent Excellent	Good Good	Excellent Excellent	Very good Difficult
Available sizes	Tube Outside Diameter 4 mm to 42 mm for DPR/PSR Triple-Lok® 6 mm to 50 mm and 1/4 in to 2 in	Tube Outside Diameter 4 mm to 42 mm for DPR/PSR/EO-2 Triple-Lok® and O-Lok® 6 mm to 50 mm and 1/4 in to 2 in	Tube Outside Diameter 6 mm to 42 mm for DPR/PSR	Tube Outside Diameter 6 mm to 42 mm for for DPR/PSR/EO-2 Triple-Lok® and O-Lok® 6 mm to 50 mm and 1/4 in to 2 in	Tube Outside Diameter 4 mm to 42 mm for DPR/PSR/EO-2 Triple-Lok® and O-Lok® 6 mm to 50 mm and 1/4 in to 2 in
Available threads	Metric ISO 9974-3 BSPP ISO 1179-4 DIN 3852 Form B NPT/NPFT	Metric ISO 6149 Metric ISO 9974-2 BSPP ISO 1179-2 UN/UNF	Metric ISO 9974-3 BSPP ISO 1179-4 DIN 3852 Form B NPT/NPFT	Metric ISO 6149 Metric ISO 9974-2 BSPP UN/UNF	Metric ISO ISO 6149 Metric ISO 9974-2 BSPP ISO 1179-2 UN/UNF
Current use	preferred use is not critical when space		not for new design	general use	general use
Typical Applications	Agricultural Equipment process engineering	All hydraulic + pneumatic systems	Agricultural Equipment process engineering	All hydraulic + pneumatic systems	All hydraulic + pneumatic systems

**Orientable Fitting Selection**

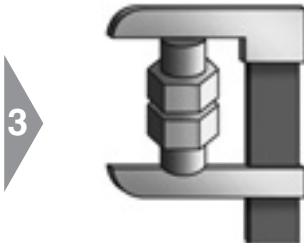

**Space**  
 ● select optimum solution for available space and best flow

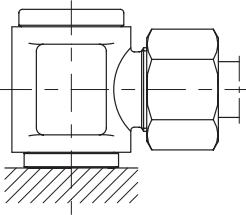
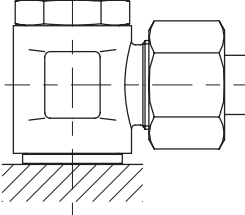
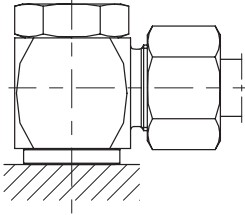
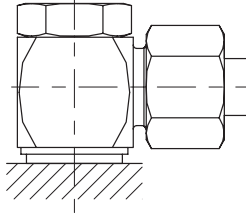

**Assembly**  
 ● check, if assembly process is suitable

Type	Banjo		High pressure banjo	
				
EO:	DSVW	SWVE	WH DKA	WH KDS
Triple-Lok®:	–	–	–	–
O-Lok®:	–	–	–	–
Design	Fitting body with hollow bolt and cap	Fitting body with hollow bolt	Fitting body with hollow bolt	Fitting body with hollow bolt
Sealing method	Metal	Metal	Metal	Elastomeric
Performance pressure Seal reliability Flow characteristics Compactness	Low pressure Good Good Excellent	Good Good Good Excellent	Very good Good Good Excellent	Very good Excellent Good Excellent
Assembly/Installation Field repair	Good Good	Very good Good	Very good Good	Excellent Excellent
Available sizes	Tube Outside Diameter 4 mm to 42 mm for DPR/PSR	Tube Outside Diameter 4 mm to 42 mm for DPR/PSR	Tube Outside Diameter 6 mm to 42 mm for DPR/PSR	Tube Outside Diameter 6 mm to 42 mm for DPR/PSR/EO-2
Available threads	– Metric DIN 3852 BSPP –	– Metric BSPP –	– Metric BSPP –	– Metric BSPP –
<b>Current use</b>	Low pressure systems only, not for new designs	Low pressure systems only	Best solution for limited application space	
<b>Typical Applications</b>	Airbrake systems Return lines	Low to medium pressure systems	Space critical applications such as: forklift trucks Mobile hydraulics	

## Standardisation



5

- Specification**
- select fittings according to international standardisation
  - check specification of end-customer/end user
  - consider project-specific guidelines
  - avoid non-standard items

ISO-fitting standards				National Standards	
<b>EO 24° fittings</b> DIN EN ISO 8434-1/-4 (former: DIN 2353)	<b>Triple-Lok®</b> ISO 8434-2 ● 37° flared fittings	<b>O-Lok®</b> ISO 8434-3 ● O-ring face seal fittings	<b>K4 Adapter</b> ISO 8434-6 ● BSPP 60° cone adapter	<b>P4 Adapter</b> JIS B 8363 JIS BSPP 60° cone dapter	<b>NPSM-Adapter</b> SAE J 516 NPTF 30° cone

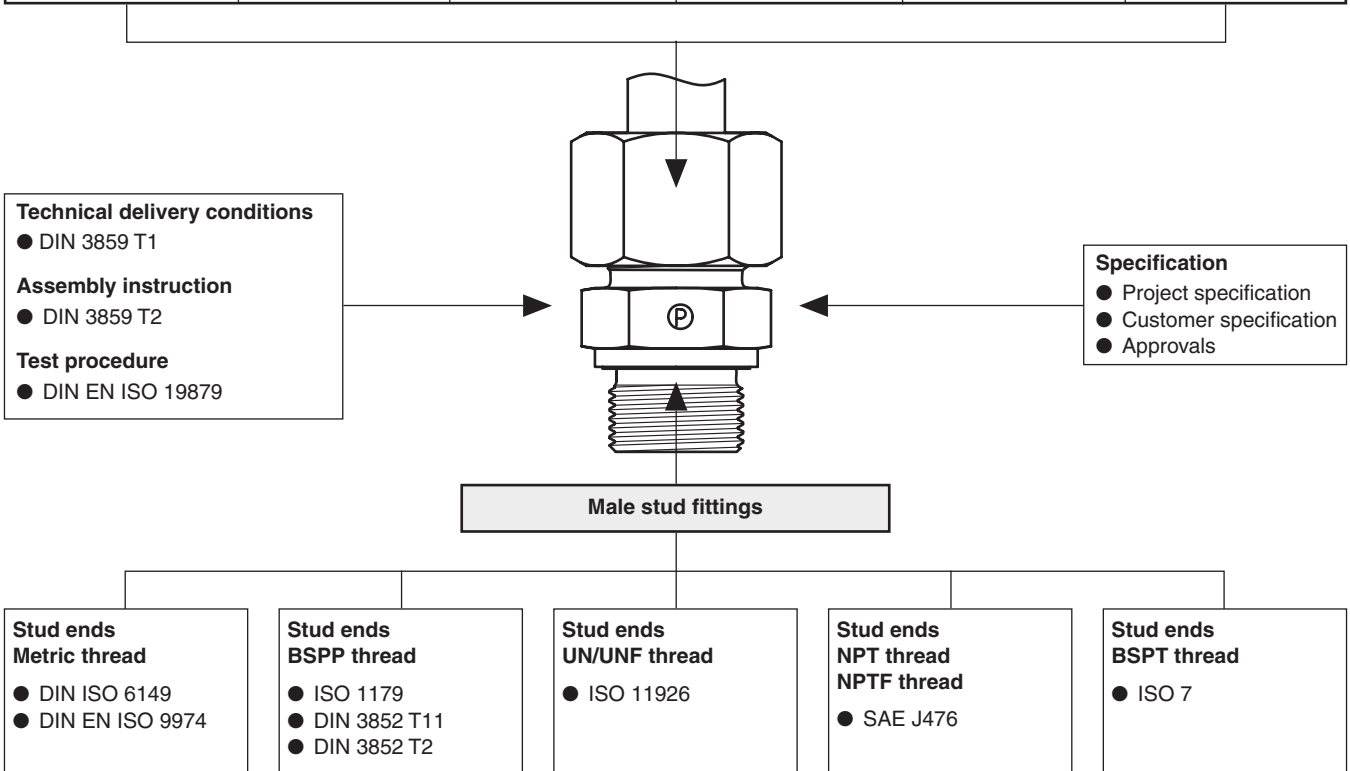

## Approvals

Parker tube fittings are recognized by various acceptance organizations, among which are:

- Germanischer Lloyd (GL)
- Lloyds Register of Shipping (LR)
- Det Norske Veritas (DNV)
- American Bureau of Shipping (ABS)
- Russian Maritime Register of Shipping (RMS)
- China Classification Society (CCS)
- Deutscher Verein des Gas- und Wasserfaches (DVGW)

For other applications, Parker tube fittings also approved by diverse national authorities.

Numerous original equipment manufacturers and end-users of various industries have approved Parker tube fittings.

**Attention:**

Type Approvals usually are limited to certain products, applications, working conditions, validity time or other restrictions. We gladly inform you on your individual application and send out the required documentation.

## Tube Specifications

### Tubes with metric outside diameters

Tube material Steel	Speci- fication	Construction	Condition	Tolerances OD/ wallthickness	Surface	Suitable fitting systems				Note
						DPR/PSR/ EO-2	EO-2 Form	T- Lok®	O-Lok®	
E235 (= 1.0308)	DIN EN 10305-4	Seamless cold drawn	+N (= normal annealed)	EN 10305-4	phosphated, oiled or A3C or CF	X	X	X	X	1)
R37	ISO 3304		NBK (= normal annealed)	ISO 3304		X	X	X	X	2)
E355 (= 1.0580)	DIN EN 10305-4		+N (= normal annealed)	EN 10305-4		X	X	X	X	3)
R50	ISO 3304		NBK (= normal annealed)	ISO 3304		X	X	X	X	4)

Tube material Stainless steel	Speci- fication	Construction	Condition	Tolerances OD/ wallthickness	Surface	Suitable fitting systems				Note	
						DPR/PSR/ EO-2	EO-2 Form	T- Lok®	O-Lok®		
1.4571 (= TP 316 Ti)	DIN EN 10216-5	Seamless cold drawn	CFA	DIN EN 10305-1	plain	X	X	X	(X)	5)	
1.4541 (= TP 321)						X	(X)	X	(X)	6)	
1.4404 (= TP 316L)	EN ISO 1127 or ASTM A269/A213		Solution heat treated (bright annealed)	D4/T3* (EN ISO 1127) or ASTM A269/A213		X	(X)	X	X	7)	
1.4301 (= TP 304)						X	(X)	X	X	8)	
1.4306 (= TP 304L)	EN ISO 1127	Welded tube	DIN 17457-K2 for OD 6–12 mm, cold drawn welded (CDW) with smooth outer surface for OD 14–42 mm	ASTM A269/A213	plain, weld seam approx. invisible	X	(X)	X	X	9)	
1.4401 (= TP 316)						X	(X)	(X)	(X)		10)
1.4541 (= TP 321)						X	(X)	(X)	(X)		

Tube material Copper	Speci- fication	Construction	Condition	Tolerances OD/ wallthickness	Surface	Suitable fitting systems				Note
						DPR/PSR/ EO-2	EO-2 Form	T- Lok®	O-Lok®	
Cu DHP R290/250/200	EN 1057 EN 12449	Seamless tube	EN 1057 EN 12449	EN 1057 EN 12449	clean, smooth plain	X	X	X	X	11)

- 1) Recommended EO standard precision tubes for high pressure hydraulic applications. Tight tolerances for easy handling. Good bendability and weldability.
- 2) Tolerance on large tube OD's not as tight as EO tube.
- 3) Precision tubes for very high pressure hydraulic applications. Tight tolerances for easy handling. Good bendability and weldability.
- 4) Tolerance on large tube OD's not as tight as EO tube.
- 5) Recommended EO standard precision tubes for high pressure hydraulic applications. Tight tolerances (same as steel tubes) for easy handling. Good weldability and corrosion resistance. ( ) = on request
- 6) Recommended EO standard precision tubes for high pressure hydraulic applications. Tight tolerances (same as steel tubes) for easy handling. Good weldability. ( ) = on request
- 7) Common tube, OD. tolerance not as tight as EO tube. Good weldability and corrosion resistance. ( ) = Tolerance at 42 mm tube OD is too large
- 8) Common tube, OD. tolerance not as tight as EO tube. ( ) = Tolerance at 42 mm tube OD is too large
- 9) Common tube, OD. tolerance not as tight as EO tube. ( ) = Tolerance at 42 mm tube OD is too large
- 10) Used in Pneumatic (low pressure) applications. ( ) = Only for tube with smooth outer and inner surface.
- 11) Support sleeve "VH" may be required, e.g. for R250-28x1.5.

\* = For DPR/PSR/EO-2 systems: thin walled tubes which need a support sleeve require tighter tolerance class T4. Tube O.D. tolerance class D3 is not recommended. D3 may reduce function and capability of the tube connection systems.

## Systematic fitting selection

### Tube Specifications

Tubes with imperial (inch) outside diameters

Tube material Steel	Specification	Construction	Condition	Tolerance OD/ wallthickness	Surface	Suitable		Note
						T- Lok®	O-Lok®	
Carbon steel C-1010	SAE J524 (AMS 5050 J, ASTM A179)	Seamless	Fully annealed	SAE J524 (AMS 5050 J, ASTM A179)	plain, oiled	X	X	1)
	SAE J525	Welded and drawn		SAE J525		X	X	2)

Tube material Stainless steel	Specification	Construction	Condition	Tolerance OD/ wallthickness	Surface	Suitable		Note
						T- Lok®	O-Lok®	
1.4404 (= TP 316L)	ASTM A269, ASTM A213	Seamless	Fully annealed	ASTM A269, ASTM A213	plain	X	X	3)
1.4301 (= TP 304)						X	X	4)
1.4401 (= TP 316)						X	X	
1.4404 (= TP 316L)	ASTM A249, ASTM A269	Welded and drawn		ASTM A249, ASTM A269		X	X	
1.4301 (= TP 304)						X	X	
1.4401 (= TP 316)						X	X	

Tube material Copper	Specification	Construction	Condition	Tolerance OD/ wallthickness	Surface	Suitable		Note
						T- Lok®	O-Lok®	
Copper	SAE J528 (ASTM B-75)	Seamless	Soft annealed Temper "O"	SAE J528 (ASTM B-75)	plain	X	X	4)

- 1) Recommended EO tubes for Hydraulic/Pneumatic applications
- 2) Common tubes in North-America
- 3) Recommended tubes for Hydraulic/Pneumatic applications. Good weldability and corrosion resistance
- 4) Tubes in North-America

## Fitting selection summary

Traditional bite-type fittings have been originally developed and designed for operating conditions of fluidpower systems completely different from today's and future market requirements.

New products and improved assembly technologies have been developed and introduced by Parker to fulfill today's and future requirements of the operators of fluidpower equipment. This new tube fitting generation and the according assembly methods are classified as *Dry Technology*. All qualifying products are explicitly *Dry Technology*-labelled throughout this catalogue.

For all new designs of

- hydraulic systems
- pneumatic systems,
- coolant systems,
- lubrication systems and
- sprinkler systems

only *Dry Technology*-classified components should be selected.

## Dry technology versus traditional technology

### EO-2 versus bite type

- + Elastomeric seal
- + Sufficient seal volume to compensate tube tolerance
- + High degree of fine sealing
- + Long-term reliability without retightening
- + No air ingress
- + Clear hit-home-feel at assembly
- + Easy assembly check
- + Integrated preassembly tool
- + No stress of inner cone of fitting body
- + No wear of preassembly tools
- + Direct assembly of stainless steel tubes possible (EO-2)
- + No galling of stainless steel threads
- + Existing tools and EOMAT machines can be used for efficient assembly (EO-2)
- + All parts integrated in Functional Nut (EO-2)
- + No confusion of individual ferrules
- + Less handling effort
- + Unlimited repeated assembly
- + Seal can be individually replaced
- + ISO-standardised (DIN EN ISO 8434-1)
- + Million times proven product since 1993 (EO-2)
- + Interchangeable with EO Progressive Ring (EO-2)
- Higher component cost than traditional bite-type fittings
- + Low total cost
- + Best value for end user
- + Mandatory specified from various industries, such as:  
automotive production, injection molding, mobile equipment, shipbuilding and offshore exploration
- + Globally gaining popularity

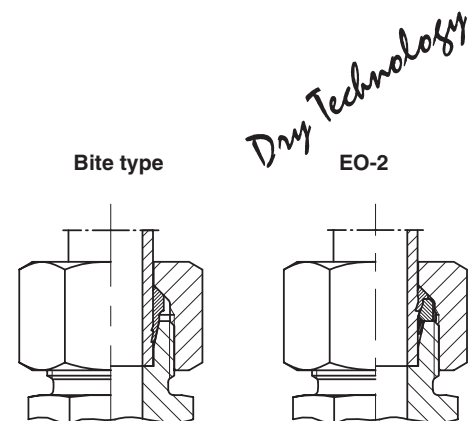

## Systematic fitting selection

### O-Lok® versus traditional Triple-Lok®

- + Higher pressure resistance than Triple-Lok®
- + Elastomeric seal
- + Sufficient seal volume to compensate tube tolerance
- + High degree of fine sealing
- + Long-term reliability without retightening
- + No air ingress
- + Clear hit-home-feel at assembly
- + Easy assembly check
- + Easy installation of flat-face components
- + Superior vibration resistance
- + Parflange® orbital flanging technology
- + Unlimited repeated assembly
- + Seal can be individually replaced
- + ISO-standardised (DIN EN ISO 8434-2)
- + Million times proven product
- Higher component cost than Triple-Lok®
- Parflange® machine required
- + braze sleeves can be used for field repair
- + Low total cost
- + Best value for end user
- + Mandatory specified from various industries, such as:  
agricultural equipment, mobile construction machines, injection molding
- + Globally gaining popularity

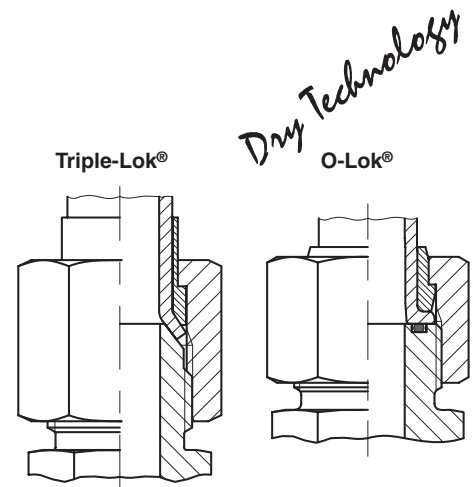

### EO2-FORM versus traditional Weld nipple

- + Safe, form-fit connection
- + Easy assembly process
- + trouble-free with zinc-plated tube
- + Elastomeric seal
- + Sufficient seal volume to compensate tube tolerance
- + High degree of fine sealing
- + Long-term reliability without retightening
- + No air ingress
- + Clear hit-home-feel at assembly
- + Easy assembly check
- + Easy tube preparation
- + Easy quality inspection
- + No rework of welding
- + Use of existing EO-2 seals
- + Unlimited repeated assembly
- + Seal can be individually replaced
- + ISO-standardised (DIN EN ISO 8434-1/-4)
- + Basic product EO-2 is million times proven
- + Interchangeable with EO Progressive Ring (EO-2)
- + No new or additional components required
- Higher component cost than traditional bite-type fittings
- EO2-FORM machine required
- + EO-2 can be used for field repair
- + Low total cost
- + Best value for end user
- + Approved for application in hydraulic presses, injection molding, lifts, waterlocks and shipbuilding
- + Globally gaining popularity

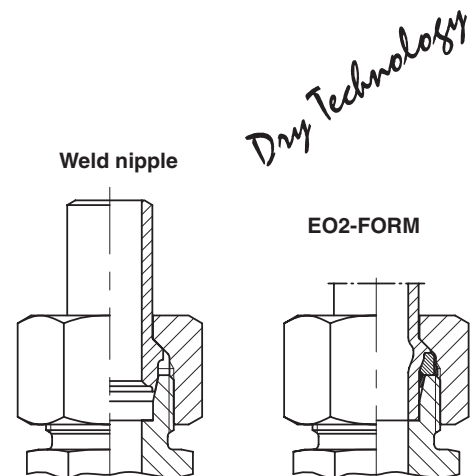

**Swivel adjustable versus traditional standpipe**

- + Elastomeric seal
- + High degree of fine sealing
- + Long-term reliability without retightening
- + No air ingress
- + Superior pressure rating
- + High mechanical strength
- + No blow-out at incomplete assembly
- + Easy fitting installation
- + No stress of inner cone of fitting body
- + No wear of preassembly tools
- + Unlimited repeated assembly
- + Seal can be individually replaced
- + ISO-standardised (DIN EN ISO 8434-1/-4)
- + Milliontimes proven product since 1970
- + Interchangeable with EO standpipe fittings
- Higher component cost than traditional standpipe fittings
- + Low total cost
- + Best value for end user
- + Mandatory specified from various industries, such as:  
automotive production, injection molding, mobile equipment, shipbuilding and offshore exploration
- + Most frequently used and still gaining popularity

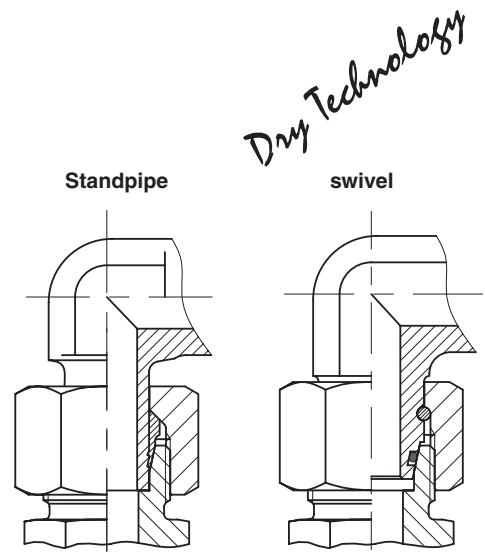

**Male stud with Elastomeric or O-ring seal versus traditional Metal seal tapered thread**

- + Elastomeric seal
- + High degree of fine sealing
- + Long-term reliability without retightening
- + No air ingress
- + Superior pressure rating
- + Clear hit-home-feel at assembly
- + No damage to port surface
- + Assembly and performance almost independant of port material
- + Low assembly torques
- + No metal sealing edge which may be damaged at transport or handling
- + Unlimited repeated assembly
- + Seal can be individually replaced
- + ISO-standardised (ISO 1179/ISO 6149/DIN ISO 6149)
- + Million times proven product since 1964
- + Interchangeable with traditional fittings
- + Wider product range and better availability
- Higher component cost than traditional bite-type fittings
- + Low total cost
- + Best value for end user
- + Mandatory specified from various industries, such as:  
automotive production, injection molding, mobile equipment, shipbuilding and offshore exploration
- + Most frequently used and still gaining popularity

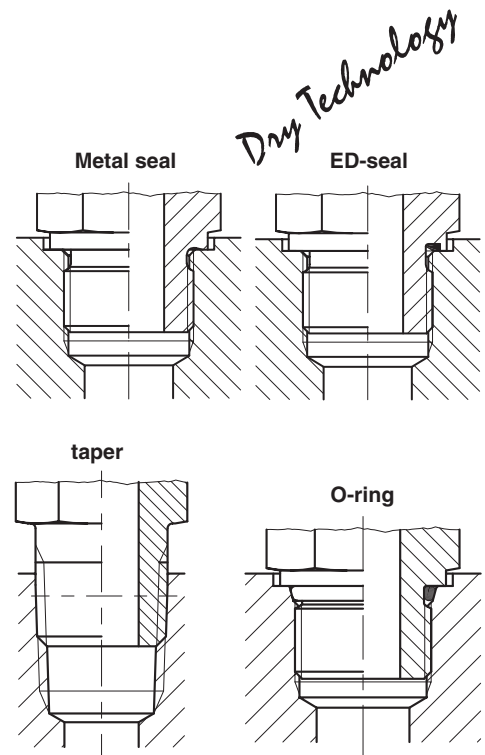

## Systematic fitting selection

---

### Locknut Adjustables versus tapered thread

- + Elastomeric seal
- + High degree of fine sealing
- + Long-term reliability without retightening
- + No air ingress
- + Good flow characteristic
- + 360° orientable
- + More compact than swivel orientable combination
- + No additional sealant required
- + Clear hit-home-feel at assembly
- + No damage to port surface
- + Assembly and performance almost independent of port material
- + Low assembly torques
- + Unlimited repeated assembly
- + Seal can be individually replaced
- + Interchangeable with traditional fittings
- + Available in 90°, 45° elbow, T- and Run-T-configuration
- Machined spot surface required
- + Lower price than Banjo fittings
- + Low total cost
- + Best value for end user
- + Globally gaining popularity

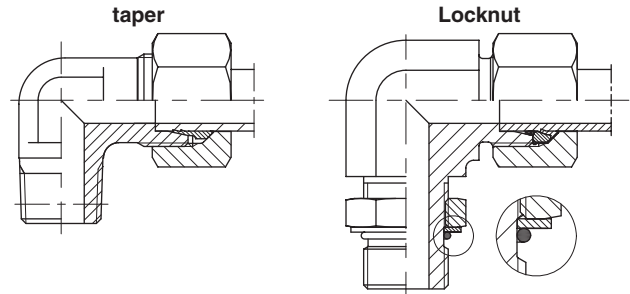

---

### High pressure banjo versus traditional low pressure elbow

- + Elastomeric seal
- + High degree of fine sealing
- + Long-term reliability without retightening
- + No air ingress
- + 360° orientable
- + Compact design
- + Suitable for high pressure applications
- + Matching small spot surface
- + Clear hit-home-feel at assembly
- + No damage to port surface
- + Assembly and performance almost independent of port material
- + Seal does not fall off
- + Only one hollow bolt needs to be tightened
- + No hidden screw
- + Unlimited repeated assembly
- + Seal can be individually replaced
- + Million times proven product since 1980
- + Interchangeable with traditional fittings
- + Available in 90°elbow and T-configuration
- Slight flow restriction
- + Low total cost
- + Best value for end user
- + Globally gaining popularity

